

# QUADCHIP

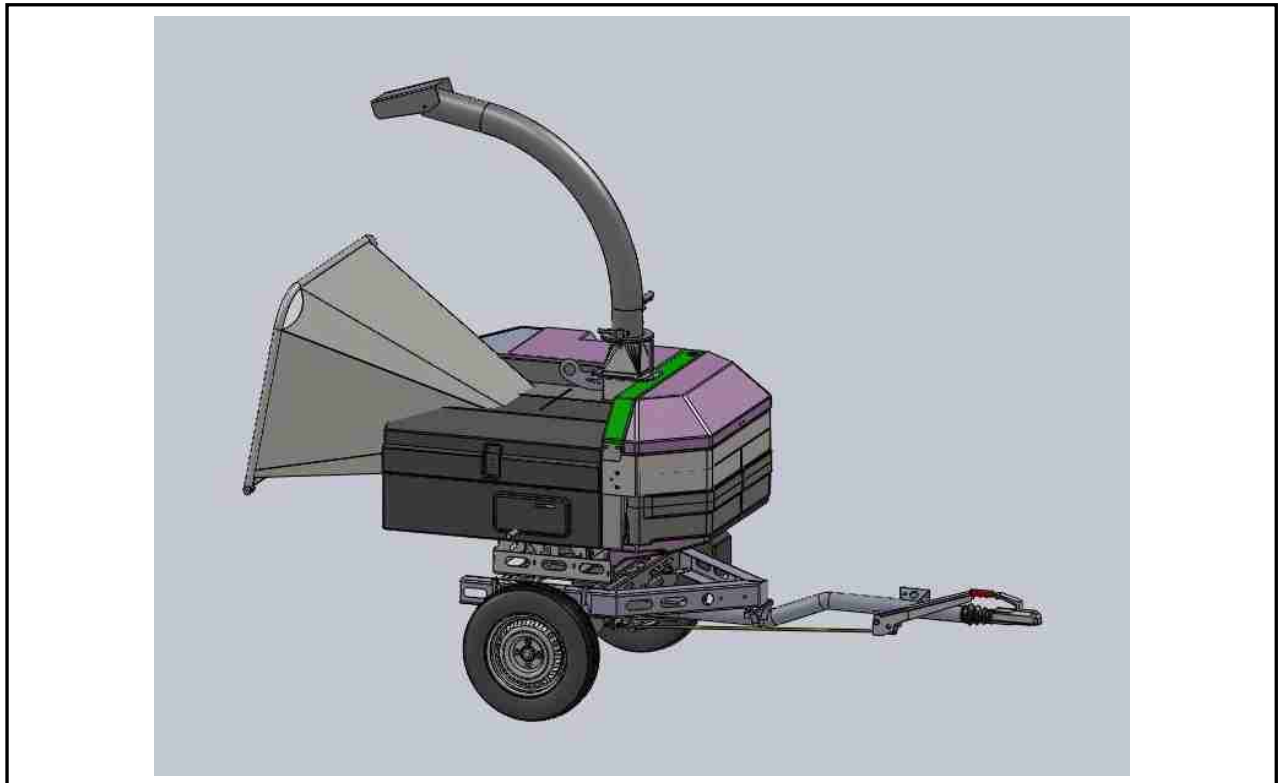

## Operator's Manual

---

**SECTION:****1. Introduction and Purpose****2. Technical Specifications, Dimensions, Noise Level, and Lifting points****3. Safety and Symbols**

- 3.1 Ensure!
- 3.2 Never!
- 3.3 Always!
- 3.4 Safety controls and switches
- 3.5 Control cut-outs
- 3.6 'No Stress' system
- 3.7 Symbols

**4. Machine Preparation**

- 4.1 Fuelling and parking
- 4.2 Drawbar adjustment
- 4.3 Infeed chute
- 4.4 Discharge chute
- 4.5 Work Position

**5. Operation**

- 5.1 Pre-work checks
- 5.2 Starting machine
- 5.3 Stopping machine
- 5.4 Blockages
- 5.5 Operating Hints
- 5.6 Preparing for Transport on completion of work

**6. Maintenance**

- 6.1 Routine Maintenance schedule and lubrication points
- 6.2 Engine Oil
- 6.3 Coolant
- 6.4 Hydraulic Oil
- 6.5 Fuel level
- 6.6 Drive belt check
- 6.7 Cutter blades
- 6.8 Radiator
- 6.9 Drive Belt replacement
- 6.10 Steam cleaning
- 6.11 Air cleaner
- 6.12 Electrics

- 6.13 Battery
- 6.14 Wheels and Tyres
- 6.15 Brakes
- 6.16 Bearings and pivots
- 6.17 Hydraulic connections
- 6.18 Mountings
- 6.19 Hydraulic return filter
- 6.20 Hydraulic Oil change
- 6.21 Fuses and No Stress system
- 6.22 Fault finding chart

## 7. Storage

- 7.1 Storage
- 7.2 Removal from storage

## 8. Disposal

## 9. Appendix

- 9.1 Hydraulic Circuit
- 9.2 Electrical Circuits
- 9.3 Certificate of Conformity
- 9.4 Risk Assessment**
- 9.5 Noise Assessment
- 9.6 Parts List
- 9.7 Transcript of HSE leaflet 604

**INTRODUCTION**

This manual explains the proper operation of your machine. Read these instructions thoroughly before operating and maintaining the machine. Failure to do so could result in personal injury or equipment damage. Consult your GreenMech supplier if you do not understand the instructions in this manual.



**CAUTION!** This symbol indicates important safety messages in this manual. When you see this symbol, be alert to the possibility of injury to yourself or others, and carefully read the message that follows.

We recommend that you keep this manual with the machine in the box provided. Locate and note here the serial number and quote it in any communications. This is important when ordering spares. Remember to include all numbers and letters.

**VIN Number.....**

**Serial Number.....**

**Write in the number!**

Fig 1.1 Serial Number plate under battery cover.



This manual covers the following models.

**Quadchip trailed chipper with top control bar, turntable**

The information in this manual is correct at the time of publication. However, in the course of development, changes to the machine specification are inevitable. Should you find any information to vary from the machine in your possession please contact your GreenMech dealer for up to date information.

This manual may contain standard and optional features and is not to be used as a machine specification.

**PURPOSE**



**CAUTION!** This machine is designed solely to chip wood and must not be used for any other purpose. The machine should only be used by trained operators who are familiar with the content of this instruction manual. It is potentially hazardous to fit or use any parts other than genuine GreenMech parts. The company disclaims all liability for the consequences of such use, which in addition voids the machine warranty.

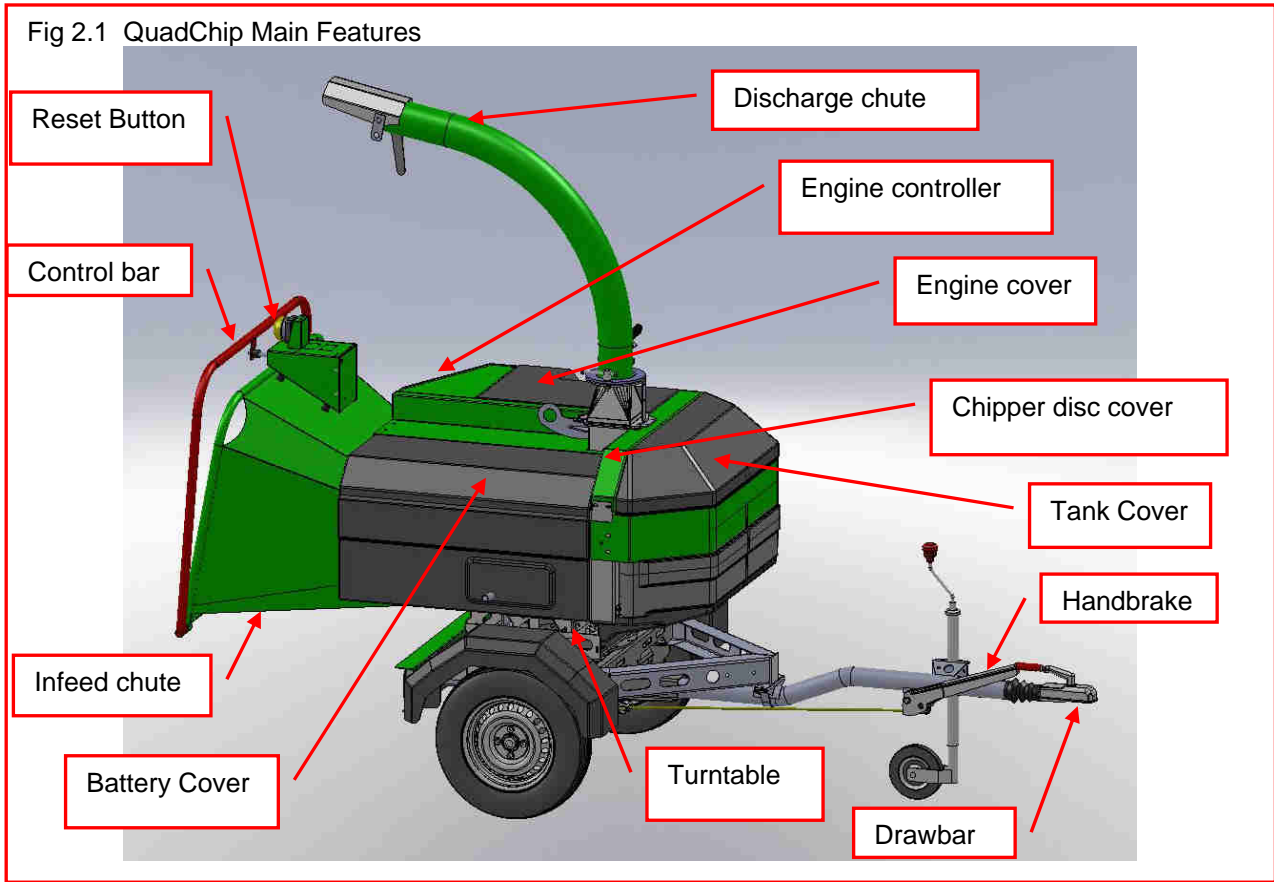

<b>TECHNICAL SPECIFICATION QuadChip 150 - 23</b>	
Max Capacity	230mm X 158mm (9inch x 6inch)
Chipping Disc	500mm x 25mm
Speed	2400 rpm
Chipping Blades	2 Square Blades
Feed Rollers	2 x Hydraulic
Power Control	No-Stress Electronic Feed Roller Controller
Power Unit	Kubota 4 cyl. / Daihatsu 3 cyl. turbo
Length (Transport)	2675mm
Length (Work)	3255mm
Width (Transport and min. for Work)	1502mm
Height (Transport)	1656mm
Height (Work)	2545mm
Weight	745Kg

**Noise**

Noise levels vary depending on type of material being processed. Also duration of operation is variable. Noise emission tests have been carried out and the guaranteed sound power level is displayed on the CE plate as follows: **Lwa 116dba (t.b.c.)**

Minimise noise by switching to idle or stopping the engine whenever chipping is not in progress.



**CAUTION!** Operators must wear appropriate ear protection. Bystanders must be kept away from proximity of machine.

**Lifting Points**

There is a single central lifting point by the base of the discharge chute.



**CAUTION!** Lift with extreme care. The machine may tilt because the single lifting point may not be directly over the centre of gravity.

**Drawbar and hitch**

Ball type hitch with overrun brake and safety cable.



**CAUTION!** Ensure that the towing vehicle is correctly suited to the trailer weight and drawbar (nose) loading. If necessary check with national vehicle legislation.

**3.1 ENSURE:**

3.1.1 All Operators must be fully trained in the use of their machine.

*(Certificated Operator training courses are available on request.)*

3.1.2 The Operators Manual is read and understood.

3.1.3 The enclosed HSE guidance notes are read and understood.

3.1.4 Appropriate Personal Protective Equipment (PPE) is worn, including non-slag clothing, gloves, eye and hearing protection.

3.1.5 The machine is positioned on level ground and the machine must be level with the infeed chute at no more than 600mm (23.62 inches) above ground level (fig 3.4.3).

3.1.6 When the unit is detached from towing vehicle the handbrake is applied and if necessary the wheels are chocked.

3.1.7 All guards are fitted and in good condition.

3.1.8 Blades are in good condition and secure.

3.1.9 All blades are sharpened or replaced in "Sets".

3.1.10 All fasteners are checked regularly for tightness.

3.1.11 Only "WOODEN" materials free of nails etc., are fed into the machine.

3.1.12 Correct First Aid Kit including large wound dressing is available on site.

3.1.13 Fire extinguisher is available on site.

**3.2 NEVER:**

3.2.1 Work on the machine until the chipper disc is stationary and engine or PTO has stopped.

3.2.2 Operate the machine without protective clothing (Eye protection, Earmuffs, and Gloves), or high visibility clothing when working on roadside.

3.2.3 Operate with loose articles of clothing, including loose cuffs on gloves.

3.2.4 Work under a raised component without adequate safety support.

3.2.5 Operate the machine with untrained personnel or with individuals present who are not involved in the chipping operation.

3.2.6 Leave the machine unattended with engine running at full operating speed.

(See section 4)

3.2.7 Put any part of your body into the infeed chute while the machine is running.

3.2.8 Operate the machine whilst under the influence of alcohol or drugs.

3.2.9 Operate inside a building or confined space.

3.2.10 Climb on the infeed chute.

3.2.11 Impede or obstruct the Stop control.

**3.3 ALWAYS:**

3.3.1 Check machine before starting (see Section 4 Preparation and Section 5.1 Operation: Pre-work checks).

3.3.2 Be aware of potential hazards in the work area, i.e. uneven ground, tree roots, trip/slip hazards, obstructions and type of materials being fed into the machine.

3.3.3 Feed from the side.

3.3.4 Keep clear of discharge area.

3.3.5 Have a second trained operator within easy reach of the machine.

3.3.6 Maintain strict discipline at all times.

3.3.7 Service machine at specified periods. (see Section 6: Routine Maintenance).

3.3.8 Note direction of discharge chute and if necessary note the wind direction to prevent debris from being blown into highway or where it could affect members of the public.

3.3.9 Remove key before doing any maintenance.

Fig 3.4.1 Control Bar and Reset Button

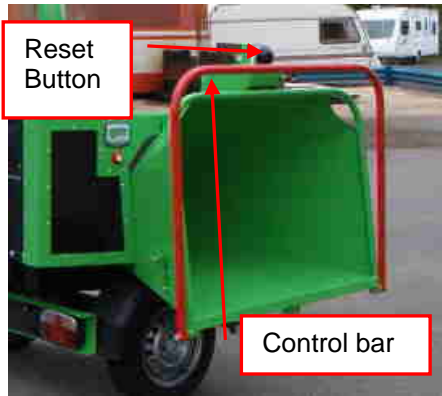

Control Bar positions  
 (Viewed towards left side of chute)  
 STOP FEED IN FEED OUT  
 ← →  
 FEED OUT FEED IN STOP  
 (Viewed towards right side of chute)

Fig 3.4.2 Engine Stop - Start

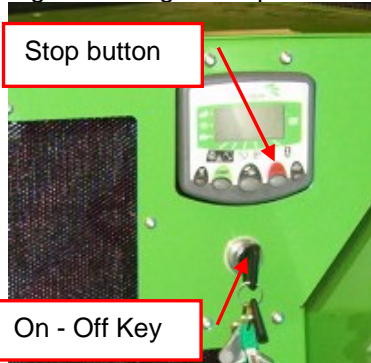

Fig 3.4.3 Infeed chute height



**3.4 Safety Controls and Switches**

**3.4.1 Emergency Stop/Control Bar (fig 3.4.1)**

In the event of an emergency, push the control bar right in to STOP the feed rollers.

3.4.1.1 Once the emergency has been rectified the following sequence should be carried out:

3.4.1.2 To restart rollers press the reset button, the control bar will have returned to the Feed In position.

3.4.1.3 Should the stop bar be tripped accidentally in normal working conditions, i.e. NOT an emergency, then the rollers can be recovered by performing the above sequence 3.4.1.2.

3.4.1.4 To reverse the rollers (feed out) pull the control bar outwards. To regain forward (feed in) push the control bar back towards the chipper.

**3.4.2 Engine Stop button**

3.4.2.1 To stop the engine, press the red stop button on the control unit, and/or turn the key anticlockwise to the '0' position. (fig 3.4.2).

3.4.2.2 To restart, reset the key clockwise to 1.

3.4.2.3 To disable the machine, remove the key.

**⚠ CAUTION! Do not restart engine until hazard has been removed.**

**3.5 Control cut-outs**

Cut-outs are installed to stop and prevent restarting due to specific events.

3.5.1 Engine overheating is protected by thermal cut-out switch in coolant circuit.

3.5.2 Low engine oil pressure is protected by pressure switch in the engine oil pump.

3.5.4 Discharge chute folded for transport is protected by a microswitch to shut off the fuel solenoid.

**3.6 No Stress system**

3.6.1 Speed sensor disables feed roller FEED IN or FEED OUT mode when engine speed is below factory pre-set value.

3.6.2 Overload sensor reverses feed to FEED OUT.

**3.7 SYMBOLS on the MACHINE**

These relate to operator safety, correct use and maintenance of machine. Check that all personnel understand and are familiar with meanings before using the machine.

**Important Safety symbols**

Take the correct action shown on the display below the stated hazard (see table)



<b>Caution!</b>		<b>Remove Key</b>		<b>Do NOT start engine</b>	
<b>Caution!</b>	Beware flying object hazard	Beware noise hazard	Beware trapping hazard	Brakes off -incorrect	
Read instruction manual	Wear helmet & visor	Wear ear protectors	Wear proper clothes	Brakes on -correct	
Machine not level -incorrect	Beware flying object hazard	Beware flying object hazard	Beware exposed drives hazard	Caution!	
Machine level -correct	Keep bystanders away	Position and lock discharge chute	Fit all guards	Keep nuts tight	

**Important Operating Checks Notice**

Before use carry out daily the stated checks in the order shown (see table)

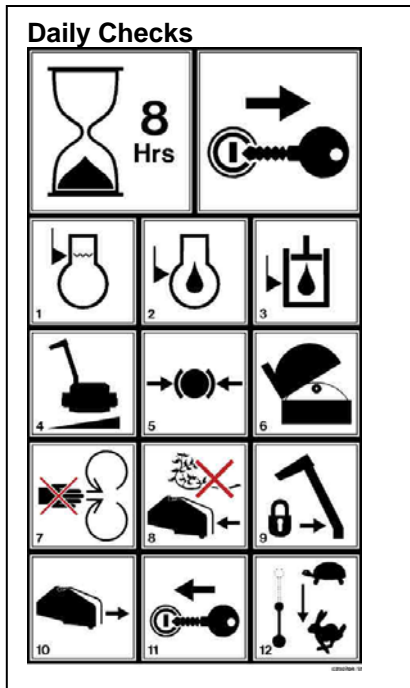

<b>Every 8 Hours – Daily checks</b>		<b>Remove key stop engine</b>	
1. Check coolant level	2. Check engine oil level	3. Check hydraulic oil level	
4. Check machine is level	5. Check brakes are on	6. Check chipper disc is clear of debris	
7. Check all guards are in place	8. Check infeed chute is clear of debris	9. Lock discharge chute	
10. Pull control bar to work position	11. Start engine	12. Increase from Idle to Run	

Important Safety Information

**Caution! Beware of thrown object hazard**



**Action: Keepaway from fast discharge chute**

**Caution! Beware of thrown object hazard**



**Action: Stand to side of infeed chute, NOT in centre.**

**Face shield must be worn**



**Wear face shield**

**Caution!**



**Do NOT operate with infeed chute at more than 600mm from ground (top bar machine).**

**Sound level**



**Ear defenders must be worn**

**Ear defenders must be worn**



**Wear ear protectors when operating this machine**

**Lift Point**



**Transport Lock**



**Lock this component before moving machine**

**Caution!**



**Do not climb into infeed chute**

**Caution! Infeed chute trapping hazards**



**Keep hands clear. Do not climb in**

Maintenance Information

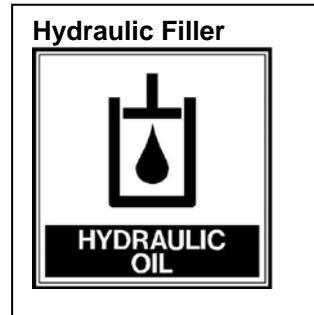
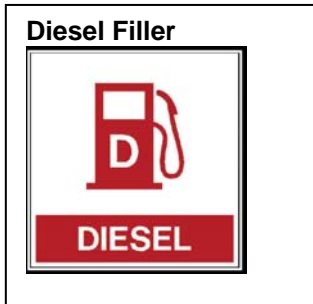

Radiator cleaning

8 Hours	40 Hours
Check radiator screen	Blow out radiator core



Operating Information

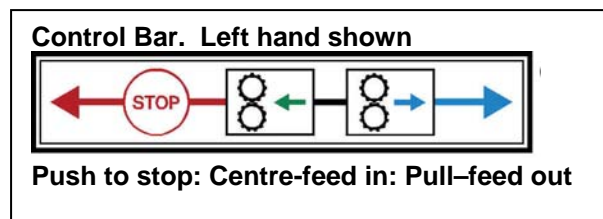
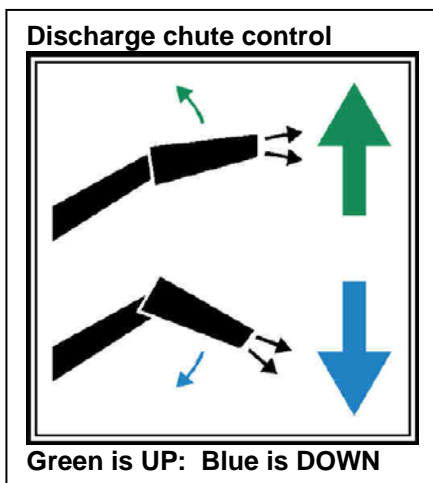

Fig 4.1 Trailer handbrake



**4.1 Initial Fuelling and Parking**

- 4.1.1 Fill the fuel tank with diesel.
- 4.1.2 Top up the hydraulic tank if necessary, with the correct oil. See Section 6.
- 4.1.3 Position the machine on firm and level ground.
- 4.1.4 Apply the vehicle handbrake.
- 4.1.5 If the machine is detached from the vehicle, set the jockey wheel clamp to allow the jack screw to lift the drawbar clear of the vehicle hitch, apply the trailer handbrake (fig 4.1) and chock the wheels.
- 4.1.6 Set the drawbar jockey wheel height to level the machine.

Fig 4.2 1 Turntable

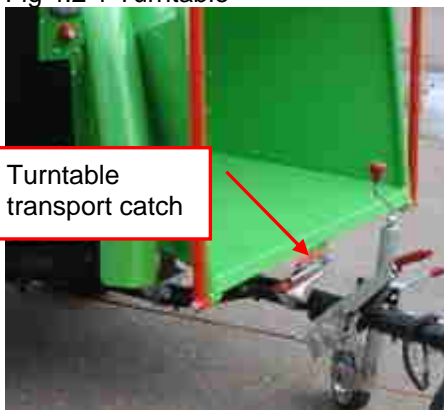

**4.2 Turntable**

To ease working on sides of busy roads the machine body can be locked in eight different working positions at 45deg steps in relation to the drawbar.

- 4.2.1 Release the transport catch.(fig 4.2.1).
- 4.2.2 Lift the locking handle (fig 4.2.2) and walk the body around to desired position.
- 4.2.3 Ensure that the body locks into new position.

**⚠ CAUTION!** A loaded vehicle increases the height of the infeed chute.

**⚠ CAUTION!** Before travelling, ensure that the turntable is rotated back into the transport position, locked and secured with transport catch.

Fig 4.2.2 Turntable Lock



**4.3 Infeed Chute**

- 4.3.1 Check the height of the infeed chute.
- 4.3.2 Press the reset button to enable the control bar to operate for use.

**⚠ CAUTION!** The infeed chute must not be used at more than 600mm from the ground. (fig 3.4.3).



Fig 4.4.1 Discharge chute transport pin

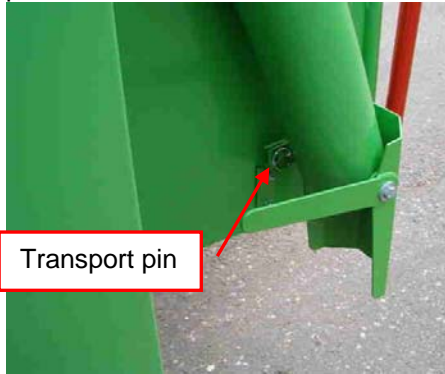

**4.4 Discharge Chute**

4.4.1 Remove the transport pin beside the infeed chute to release the discharge chute (fig 4.4.1).

4.4.2 Lift the discharge chute up into the work position.

4.4.3 Secure the hinge with overcentre clamp (fig 4.4.2) and bolt.

4.4.4 Release the swivel clamps, point the chute in the desired direction and tighten the clamps.

4.4.5 Set the flap at the desired height and tighten the clamp.

**⚠ CAUTION!** Do not point the discharge chute towards the infeed area.

**⚠ CAUTION!** Stow and secure the discharge chute in the transport position when travelling.

Fig 4.4.2 Discharge Chute (folded)

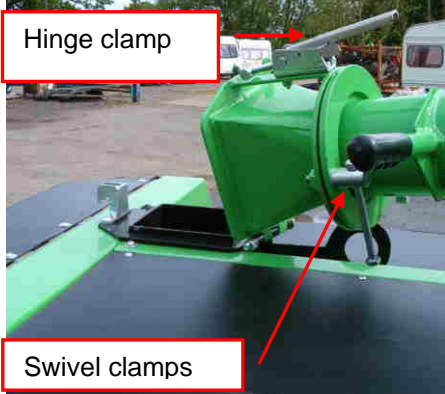

**4.5 Work Position**

Typical work position (fig 4.5) shown with infeed chute away and angled from drawbar and discharge chute pointing away from infeed.

Fig 4.5 Work position (typical)

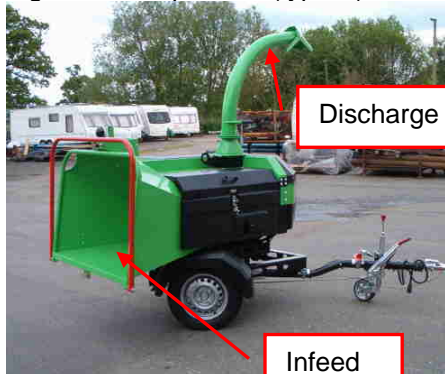

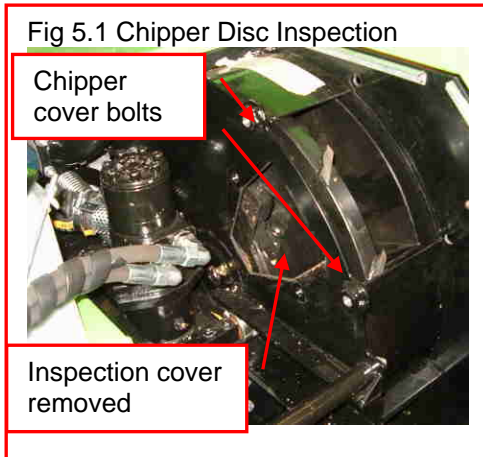

### 5.1 Pre-Work Checks:

5.1.1 Check machine is stationary, Key in OFF position or removed, and hand brake applied if separated from vehicle.

5.1.2 Check that machine is level and infeed chute is not more than 600mm from ground (fig 3.4.3).

5.1.3 Check engine oil level (See Engine instruction manual).

5.1.4 Check hydraulic oil level (See Section 6).

5.1.5 Check fasteners for tightness and hydraulic connections for leaks.

5.1.6 Check condition of disc blades.

5.1.6.1 Unlock, raise and secure rear cover and battery cover. Check nothing is rotating.

5.1.6.2 Remove chipper disc cover -2 bolts (fig 5.1.1).

5.1.6.3 Remove inspection cover -2 bolts.

5.1.6.4 Carefully rotate chipper disc to check tightness of disc blade bolts and condition of blades.

5.1.6.5 Remove any loose wood material.

5.1.6.6 If any bolts are loose, refer to maintenance section for further action.

5.1.6.7 Replace inspection cover and chipper disc cover and tighten all bolts securely.

5.1.7 Remove any loose material and dust from radiator and engine bay

5.1.8 Replace all covers and secure.

5.1.9 Check discharge chute is in desired position away from infeed and all clamps are tight. (see Section 4.4)

5.1.10 Check work area and erect signs and cone off discharge area if necessary.

5.1.11 Check **ALL** safety procedures have been followed.



**CAUTION!** Beware sharp edges of discs and unexpected movement.

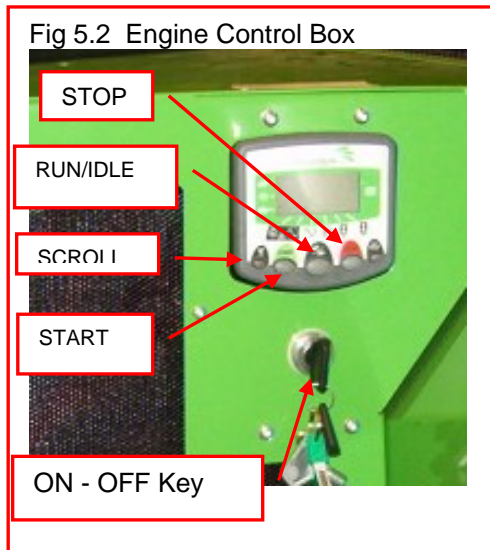

**5.2 Starting Machine (Fig 5.2)**

5.2.1 Check all other personnel are clear of machine.

5.2.2 Check that feed roller control bar is pushed to the FEED OUT or STOP position, to make the machine safe.

5.2.3 Turn the ON - OFF key to position I. Wait for the pre-glow countdown to cease and chipper speed 0 rev/min to be displayed.

5.2.4 Press green START button to start the chipper.

5.2.5 Press the RUN/IDLE button to increase the speed to operating speed.

5.2.6 Press the reset knob at control bar (fig 3.4.1) to set the control bar ready for work.

**5.3 Stopping Machine**

5.3.1 Push the control bar to STOP position.

5.3.2 Press the RUN/IDLE button and allow chipper disc to slow down (fig 5.2).

5.3.3 Press red STOP button to stop the engine.

5.3.4 Switch ON - OFF key to position 0.

5.3.5 Wait for chipper disc to stop.

**⚠ CAUTION!** The chipper disc will take several seconds to stop due to its inertia.

**5.4 Adjustable Speed Feed Roller Control (if fitted)**

When chipping wood sizes larger than 120mm diameter it may be necessary to reduce the feed roller speed to suit the material being chipped.

The control knob can be carefully accessed from the battery cover.

5.4.1 Release the back-nut and turn the valve control knob (fig 5.4) clockwise until valve is closed.

5.4.2 Turn the knob anticlockwise to the recommended setting in the table.

5.4.3 Tighten the back-nut, lower and secure the cover.

**⚠ CAUTION!** Do not leave covers open whilst machine is running.

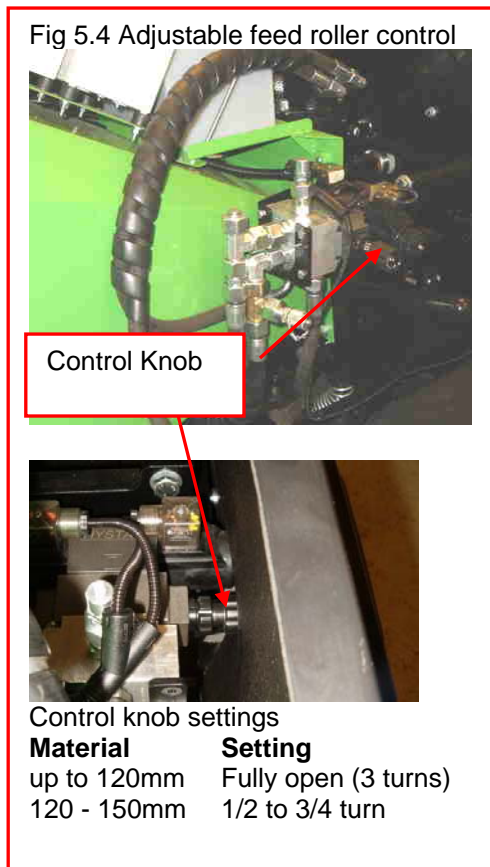

### 5.5 Operating Hints

5.5.1 Check that chipper disc is at full speed, rpm readout should be above 2300 rpm.

**NOTE:** The “No Stress” system will only allow FEED IN (Forwards) and FEED OUT operation of the feed rollers when the machine is running at FULL operating speed and not overloaded.

5.5.2 Reduce the chipper speed to IDLE whilst further material is collected for chipping.

5.5.3 Take care when feeding wood into the machine to allow for awkward shapes to “KICK” when contacting the feed rollers.

5.5.4 Position the end of larger sections of wood inside the infeed chute and then support the other end whilst pushing the wood into the feed rollers.

**⚠ CAUTION!** Do not release discharge chute clamps when chipping is in progress. Elevation of the discharge is altered by means of the adjustable flap (fig. 4.4).

**⚠ CAUTION!** Keep working area around the machine clear at all times and check only authorised personnel are present.

Fig 5.6 Machine ready for transport



- 1) Discharge chute folded and secure
- 2) Turntable set with infeed over drawbar and secured
- 3) All covers closed and locked

### 5.6 Preparing For Transport On Completion Of Work

5.6.1 Check that engine has stopped and chipper disc is stationary.

5.6.2 Remove surplus material from infeed chute and all machine surfaces.

5.6.3 Unlock, lift and secure covers to remove debris.

5.6.4 Lower discharge chute into transport position and secure with pin.

5.6.5 Rotate turntable to transport position and secure infeed chute over drawbar.

5.6.7 If detached, re-attach trailer to vehicle, raise jockey wheel, connect safety cable and electric services.

**ROUTINE MAINTENANCE SCHEDULE**

**CAUTION!** Always remove key and check for rotation before carrying out any maintenance.

**Note:** Battery, engine and tank covers are secured closed with a key. Remove when open by raising fully and lifting forward to unhook hinge. Replace when task is completed.

Action	Section	Page
<b>DAILY</b>		
Check engine oil level and coolant (ref: engine manual)	6.2 – 6.3	6-4
Check hydraulic oil level	6.4	6-4
Check fuel level	6.5	6-4
Check all drive belts	6.6	6-4
Check condition of blades and retaining bolts	6.7	6-5
<b>Note:</b> Special tools required		
Clean radiator screen and around radiator	6.8	6-6
Check feed roller control bar function	3.4	3-2
<b>First 50 hours</b>		
Check drive belt tension	6.9	6-6
Check battery levels	6.13	6-7
Check wheel and tyre condition and pressures	6.14	6-7
Check brake condition and operation	6.15	6-8
Check hydraulic connections	6.17	6-9
Check all mountings	6.18	6-9
Check feed roller control bar function	3.4	3-2
Service engine	Refer to engine manual	
<b>Weekly in addition to Daily actions</b>		
Blow out radiator core with air line	6.8	6-6
Check drive belt tension	6.9	6-6
Steam clean machine	6.10	6-6
Clean air cleaner	6.11	6-6
Check electrical connections	6.12	6-7
Check battery levels	6.13	6-7
Check feed roller control bar function	3.4	3-2
Check wheel and tyre condition and pressures	6.14	6-7
Check and adjust brakes	6.15	6-8
Grease all bearings and pivots	6.16, 6.1	6-8
Check hydraulic connections	6.17	6-9
Check all mountings	6.18	6-9
<b>250 hours in addition to Daily and Weekly actions</b>		
Check all fluid levels	6.2, 6.3, 6.4	6-4
Check brake condition and operation	6.15	6-8
Check condition of bearings and pivots	6.16	6-8
Service engine	Refer to engine manual	
Check axle mounting bolts for tightness	6.18	6-9
Replace return filter element	6.19	6-9

**1000 hours in addition to 250 hour actions**

Change hydraulic oil when replacing filter element	6.20	6-9
--	------	-----

**ENGINE MAINTENANCE**                      **REFER TO ENGINE MANUAL**

**WHEELS AND BRAKES**                      **REFER ALSO TO AL-KO CHASSIS MANUAL**

**Tyre Pressure**            **2.7 bar (40 lb/in<sup>2</sup>)**

<b>Recommended lubricants</b>	<b>Specification</b>
Hydraulic Oil	ISO 32
Grease	Complex grease EP2 (high temperature)
Engine	SAE 15W-40 APICD

6.1 Lubrication Points (see 6.14)

Fig 6.1 Lubrication points QuadChip

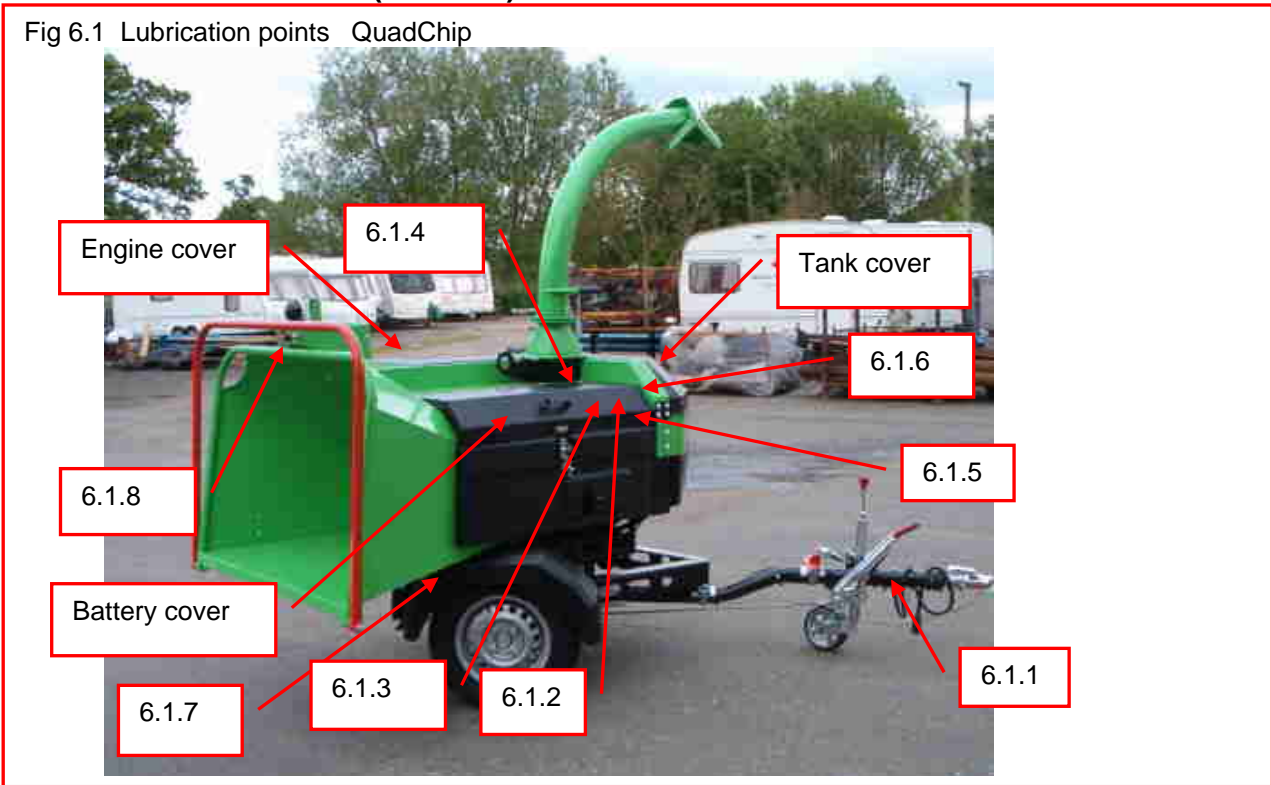

Grease except where stated

6.1.1	Drawbar	2 nipples
6.1.2	Feed roller slide	Clean and grease sparingly
6.1.3	Sliding Feed roller bearing	1 nipple under battery cover
6.1.4	Fixed Feed roller bearing	1 nipple under battery cover (see note 1)
6.1.5	Chipper Disc front bearing	1 remote feed nipple (Fig 6.1.3)
6.1.6	Chipper Disc rear bearing	1 remote feed nipple (Fig 6.1.3)
6.1.7	Turntable (if fitted)	2 remote feed nipples (Fig 6.1.3)
6.1.8	Feed Roller control	Clean and grease sparingly
6.1.9	Drive Belt Tensioner	1 nipple under tank cover (fig 6.1.4)

Note 1: Do not over-grease bearings as damage to seals may occur.

Note 2: Use high temperature grease on chipper disc bearings.

Fig 6.1.2 Grease nipples and slides under battery cover

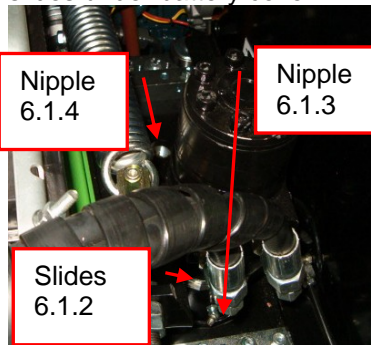

Fig 6.1.3 Remote grease nipples

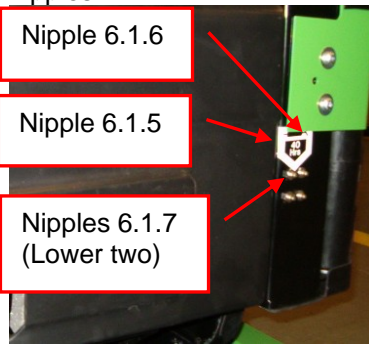

Fig 6.1.4 Grease nipple for belt tensioner under tank cover

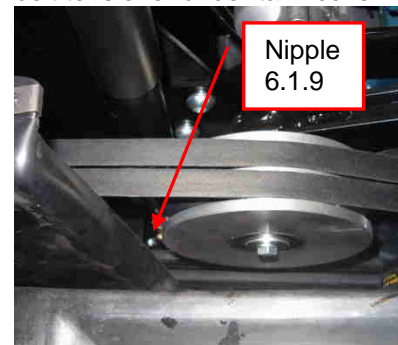
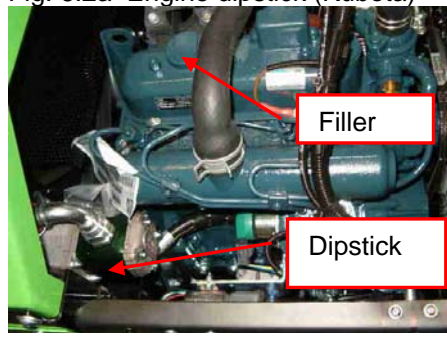

Fig. 6.2a Engine dipstick (Kubota)



**6.2 Engine Oil (Under engine cover)**

6.2.1 Check daily (fig 6.2). Refer to engine manual to refill.

Fig. 6.2b Engine dipstick (Daihatsu)

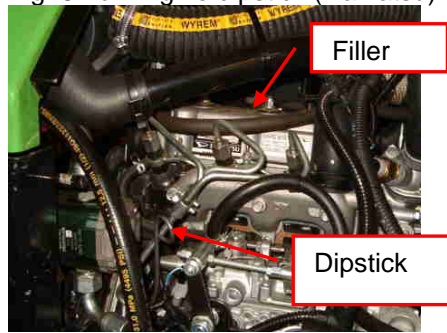

**6.3 Coolant (Under Engine cover)**

6.3.1 Check daily, both radiator and overflow tank (fig 6.3). Refill as required. Check antifreeze.

**⚠ CAUTION!** Do not remove cap when engine is hot.

**6.4 Hydraulic Oil (Under tank cover)**

6.4.1 Check daily (fig 6.4). If below mark check for leaks and refill to correct level.

6.4.2 1000 hours. Remove drain plug, drain tank and refill with clean oil of correct specification. Replace filter (6.18)

Fig.6.3 Coolant



**6.5 Fuel Level (Under tank cover)**

6.5.1 Check daily before work and fill as required (fig 6.4).

**⚠ CAUTION!** Use clean diesel fuel only. If in doubt, use a funnel with a filter.

**⚠ CAUTION!** Do not use any form of synthetic fuel.

Fig. 6.4 Under tank cover

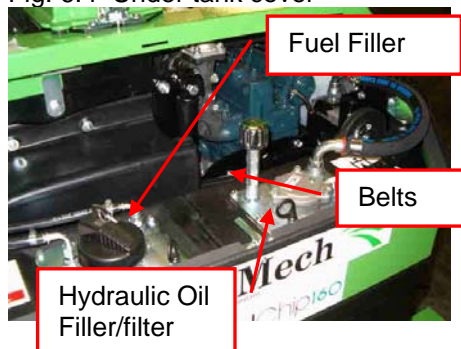

**6.6 Drive Belts (Under tank cover (fig 6.4))**

Check daily, before work, the condition of all drive belts and replace if worn. See section 6.9 for further information.

Fig 6.7.1 Chipper Disc Inspection

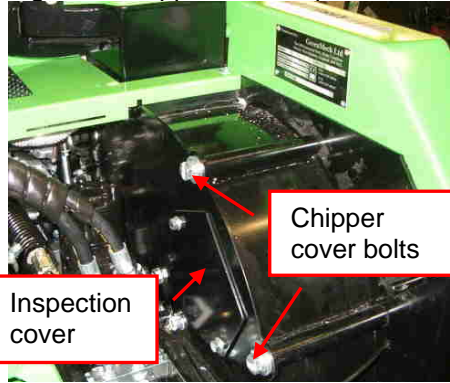

Fig 6.7.2 Chipper Disc Inspection

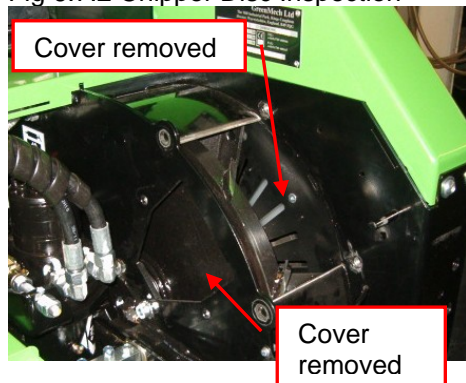
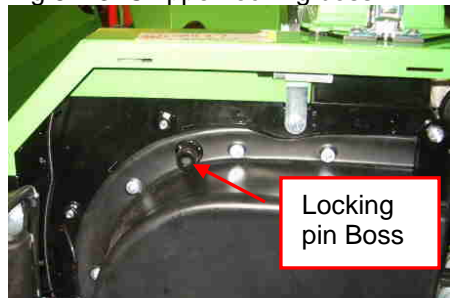

Fig 6.7.3 Chipper locking boss



**6.7 Blade Rotation and Replacement**

The design of the blades permits relocation in at least three rotated positions before regrinding or replacement is required.

6.7.1 Check engine is switched off and start knob removed.

6.7.2 Remove battery cover and tank cover. Check any rotation has stopped.

6.7.3 Remove the bolts retaining chipper disc cover and inspection cover (fig 6.7.1) and remove covers (fig 6.7.2).

**⚠ CAUTION! Beware sharp edges of blades and unexpected movement.**

6.7.4 Lock the chipper disc with a chipper disc cover bolt or suitable pin through the locking pin boss (fig 6.7.2) into a fan blade.

6.7.5 Slacken blade retaining bolt, remove cutter, and clean mounting face and location.

6.7.6 Replace blade in a rotated position to present a sharp section to the shear bars.

6.7.7 Torque up bolt to 150NM (110lb.ft.)

6.7.8 Remove locking pin and rotate disc to next position.

6.7.9 Check condition and security of shear bars. Rotate or replace if required. Do not regrind.

6.7.10 Replace and secure all covers.

**⚠ CAUTION! Blades must only be sharpened by grinding the angled back face on a bench grinder. Grinding of the front face will upset the gap, which is factory set. Do not sharpen with hand held equipment.**

Note. If any of the blades are worn below the flat annular section a complete set should be replaced. Inspect condition of nuts and bolts and replace if any signs of wear.

All blades must be sharpened in “sets” with equal amounts removed to maintain balance.

Fig.6.8 Radiator

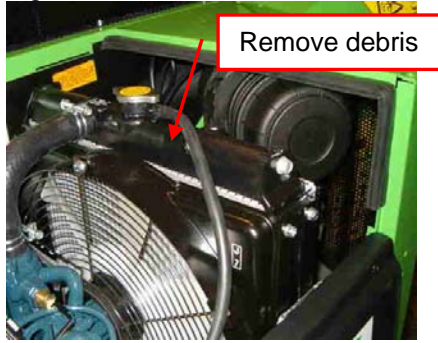

**6.8 Radiator (under engine cover)**

**Daily**

6.8.1 Check radiator for debris. (fig.6.8)

**50 hours or weekly**

6.8.2 In addition to above, blow out radiator core from back with suitable airline and clear from front.

**⚠ CAUTION!** A build up of debris risks overheating of the engine and a risk of fire.

Fig 6.9.1 Drive Belt tensioner

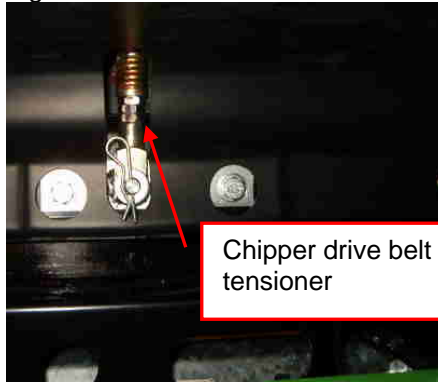

**6.9 Drive belts**

**Belt Replacement**

6.9.1 Remove tank covers from machine (fig 6.9.1).

6.9.2 Hinge tanks away from drive belt area (fig 6.9.2).

**Chipper Drive**

6.9.3a Remove fan cover.

6.9.4a Release nuts on idler pulley tensioner bar until belts are slack enough to be removed.

**Pump drive**

6.9.3b Release 4 bolts in slotted pump mounting plate to permit belts to be removed.

6.9.5 Fit new set of belts ensuring they lay snugly in pulley grooves.

6.9.6a Screw nuts on tensioner bar to re-tension belts.

6.9.6b With suitable bar ease pump plate upwards to tighten belts and secure plate with bolts.

6.9.7 Check tension.

6.9.8 Replace fan cover if removed, reposition tanks, replace all covers and secure.

Fig 6.9.2 Drive Belt access

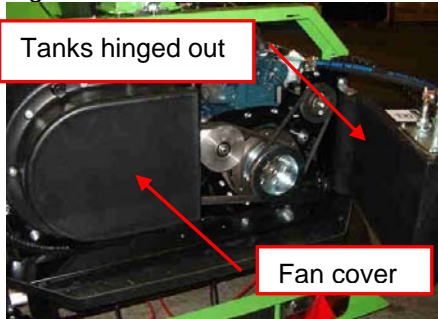
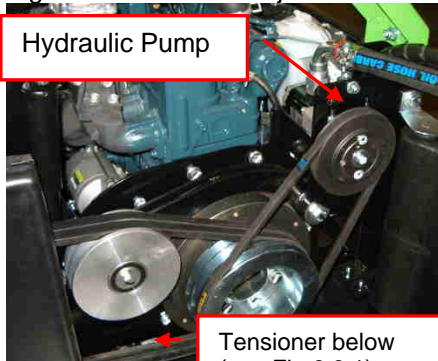

Fig 6.9.3 Drive Belt adjustments



**6.10 Steam Cleaning**

**Weekly and every 250 hours**

6.10.1 Check all covers are fitted and closed.

6.10.2 Steam clean machine surfaces.

6.10.3 Clean electrical components with a damp rag, spray with WD40 and then wipe with dry rag.

**⚠ CAUTION!** Do not steam clean directly on to electrical components, e.g. control boxes.

Fig 6.11 Air Cleaner



### 6.11 Air Cleaner (under engine cover) Weekly (Refer to engine manual)

6.11.1 Remove cover clips (fig 6.11) and release.

6.11.2 Slide out element and either blow out with air-line or gently tap on smooth ground to release debris.

6.11.3 Replace cover.

### 6.12 Electrical connections weekly

6.12.1 Check all wiring loom connections are secure.

**⚠ CAUTION!** Poor connections will affect engine security cut-outs and may prevent starting.

### 6.13 Battery

#### First 50 hours and weekly

6.13.1 Remove battery cover.

6.13.2 Release stays to access battery.

6.13.3 Check electrolyte level and top up if required.

6.13.4 Reposition battery, and secure stays.

6.13.5 Refit cover and secure.

#### Removal

6.13.6 First disconnect negative (-) cable (black cap).

6.13.7 Disconnect positive (+) cable (red cap).

6.13.8 Remove clamp and carefully lift out battery.

6.13.9 Replace by connecting positive cable before negative.

6.13.10 Secure battery as 6.13.4 above.

**⚠ CAUTION!** Gases are explosive. Electrolyte is corrosive. Avoid sparks and spillage.

Fig 6.13 Battery

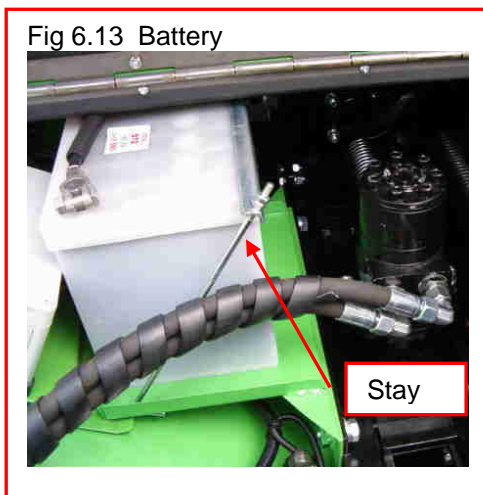

### 6.14.4 Tyre sealant

Tyres installed with Air-Seal Products water based sealant have either green valve cap or green ring around valve. Tyres will operate in same fashion as normal pneumatic tyre.

**Note** If valve core is depressed to deflate tyre, valve recess may become blocked with plug of sealant. To unblock either remove valve core to allow air to blow plug out or alternatively blow plug back into tyre with airline.

For replacement supply, consult GreenMech or distributor.

### 6.14 Tyres and Wheels 50 hours and 250 hours

6.14.1 Check condition of tyres.

6.14.2 Check pressures and inflate to 2.7bar (40lb/in<sup>2</sup>) pressure as required.

6.14.3 Check wheel nuts are tight to 110Nm (80lbft) torque.

Fig 6.15.1 Brake adjustment



Fig 6.15.2 Brake adjustment

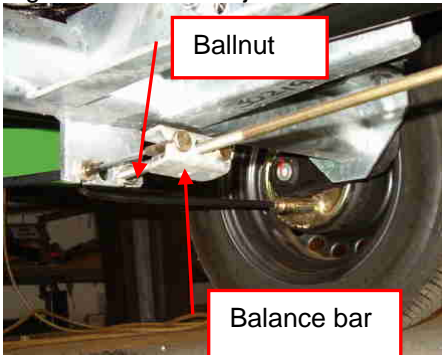

**6.15 Brakes**

**50 hours, weekly and 250 hours**

6.15.1 Check operation and effectiveness of overrun and handbrake.

**100 hours**

**Adjust brakes as follows**

6.15.2 Chock machine, release handbrake fully off and check drawbar is fully extended.

6.15.3 Jack up both wheels and support on axle stands.

6.15.4 Remove inner bung to expose adjuster 'starwheel' (fig 6.15.1).

6.15.5 Adjust starwheel with screwdriver until tight whilst rotating each wheel forwards until tight.

6.15.6 Slacken until wheel rotates freely in forward direction.

6.15.7 Check brake linkage has 4 to 6mm movement at cable.

6.15.8 Repeat for opposite wheel.

6.15.9 Check balance bar is straight and pulls both cables evenly (fig 6.15.2).

6.15.10 Adjust the ballnut to remove any slack from brake rod.

**Note:** Servicing of brakes may be required more often if above average mileage is covered.

Refer to AL-KO brake manual or GreenMech for details for brake shoe replacement and other servicing

**⚠ CAUTION!** Reverse rotation of wheel may prevent correct adjustment.

**6.16 Bearings and Pivots weekly**

See paragraph 6.1 for routine lubrication.

**250 hours**

6.16.1 Check rotating components for excessive movement and noise in operation.

6.16.2 Replace as required.

**Note:** Wheel bearings are maintenance free and do not require attention.

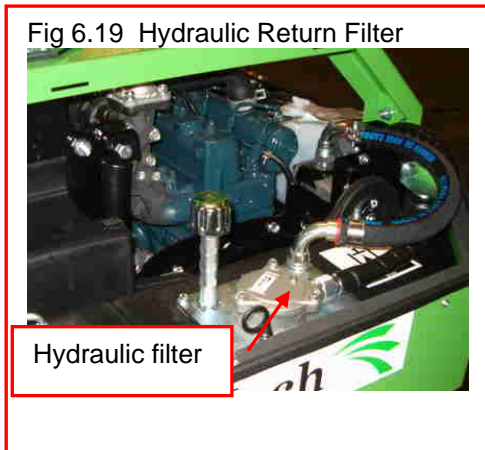

### 6.17 Hydraulic connections

#### 50 hours

6.17.1 With the aid of the circuit diagram to follow the hose routings, check all hoses and connections for leaks and damage.

6.17.2 Replace any worn or damaged hoses with the correct type and length.

6.17.3 Before removal, check routing and ensure replacement hose is fitted free of strains, twists or kinks.

**⚠ CAUTION!** Ensure any residual pressure is released before dismantling.

**⚠ CAUTION!** Ensure hoses are refitted free of twists and kinks.

### 6.18 Mountings

#### 250 hours

6.18.1 Check that all mounting bolts are tight.

### 6.19 Hydraulic Return Filter

#### 250 hours

6.19.1 Check oil is cool.

6.19.2 Unscrew the filter cover (there is a spring under the cover) and carefully lift out the element, it may require gentle prising out, discard safely (fig 6.19).

6.19.3 Fit a new filter element to the correct specification and replace the cover and spring.

**⚠ CAUTION!** Do not overtighten.

### 6.20 Hydraulic Oil change

#### 1000 hours

6.20.1 Remove hydraulic oil with suction pump at filter/filler and replace with new oil and filter of correct specification.

6.20.2 Replace suction filter.

6.20.3 Dispose of waste oil according to local authority environmental procedures.

**6.21 Fuses and No Stress system**

There are two fuses.  
 A 40 amp in-line fuse protects the engine pre-heat and start circuit.  
 A 20 amp fuse protects the Power Protection System.

Note The engine operating speeds for the No Stress system are factory set for particular machine builds and must not be readjusted.

**6.22 Fault finding**

<b>Fault</b>	<b>Check</b>	<b>Action</b>	<b>Page</b>
Engine will not start	Covers and discharge chute cut-out switches	Secure guards and Chute	
	Battery	Recharge	6-7
	Fuel	Fill tank	6-4
	Oil pressure	Check Oil level	6-4
	Thermal cut-out	Check operation	6-4
	Fuses	Check	6-9
Engine not at correct speed	Engine control	Check operation	5-2
Chipper disc will not start	Drive belts	Replace	6-6
Feed rollers do not turn	Control bar	Reset and check	3-2
	Hydraulics	Check solenoid valve	
Feed will not reverse	Control bar	Reset and check	3-2
	Hydraulic valve	Check operation	
Discharge does not flow	Discharge chute	Check for blockage	4-2
	Chipper disc	Check for blockage	5-1
Unusual noise(s)	Chipper disc and bearings	Check and replace	5-1

**7.1 Storage**

- 7.1.1 Thoroughly clean machine and note any replacement parts required.
- 7.1.2 Carry out 250 hour service if not already done. Refer to Section 6
- 7.1.3 Fit replacement parts when available.
- 7.1.4 Remove battery Refer to 6.13
- 7.1.5 Drain fuel
- 7.1.6 If machine is to be stored for more than 3 months, place on axle stands to remove weight from wheels.

**7.2 Removal from Storage**

- 7.2.1 Charge battery and refit Refer to 6.13
- 7.2.2 Check tyre pressures Refer to 6.14
- 7.2.3 Check brake operation Refer to 6.15
- 7.2.4 Carry out machine preparation as necessary Refer to Section 4

When the machine is finally scrapped, the following items should be disposed of only at authorised waste disposal facilities.

Engine oil. Hydraulic oil. Antifreeze. Battery. Tyres.

If in doubt, consult the Local Authority environmental department.

Major non-ferrous items such as covers and hydraulic hoses may also be disposed of separately.

**Safety Guides and Checklist as  
Transcribed from and Advised by  
Arborculture & Forestry Advisory Group  
and Issued as Leaflet 604 by HSE, issued  
04/03**

### INTRODUCTION

This leaflet covers the safe working practices to be followed when operating a wood chipper.

It does not cover a combination of machines working within each other's risk zones (see AFAG leaflet 605 *Mechanical roadside processing*)

You can use this leaflet, along with the manufacturer's handbook, as part of the risk assessment process to help identify the controls to put in place when using a wood chipper.

You must also assess the effect of the site and the weather as well as following this guidance

All operators must have had appropriate training in how to operate the machine and how to carry out the tasks require (see AFAG leaflet 805 *Training and certification*)

### PERSONAL PROTECTIVE EQUIPMENT (PPE)

1. Use the following PPE
  - A Safety Helmet, complying with EN 397, if identified as required in the risk assessment.
  - Eye Protection (a mesh visor complying with EN1731 or safety glasses to EN166)
  - Hearing protection (complying with EN352) where noise level exceeds 85 dB(A) (see HSE pocket card INDG363 *Protect your hearing or lose it!*)
  - Gloves.

- Safety Boots with good grip and ankle support (complying with EN345-1)
- Non-Snag Outer Clothing appropriate to prevailing weather conditions. High-visibility clothing (complying with EN471) should be worn when the risk assessment identifies that it is needed.

2. Each person should carry a personal first-aid kit including a large wound dressing (see HSE leaflet INDG214 *first aid at work; Your questions answered*).
3. Hand cleaning material such as waterless skin cleanser or soap, water and paper towel should be readily available.

### THE MACHINE

4. Before working with a machine, check it has been properly converted from any transport mode.
5. Ensure guards for dangerous parts (e.g. belts, pulleys, shafts etc) are secure and undamaged.
6. Ensure protective devices, such as the infeed control bar (incorporating the stopping device), are working correctly (see HSE leaflet AI S 38 *Power-fed mobile wood chippers: Operator protection at infeed chutes*).
7. Ensure any lock for the chipping components has been disengaged;
8. Ensure the infeed hopper is clear of any materials.
9. Ensure Noise warning signs are in place.
10. For machines driven by a power take-off (PTO) shaft, before starting ensure:

- The PTO shaft is fitted with a suitable guard complying with EN1152, that encloses the shaft along its full length from tractor to machine.
- The guard is correctly fitted and in effective working order (see AS24(rev) *Power take-offs and power take-off drive shafts*);
- The PTO speed is suitable for the machine.

### **SELECTING THE WORK AREA**

11. Select as firm a surface as possible and stabilise the machine
12. Ensure ventilation is adequate and any exhaust fumes are vented into open air if working in an enclosed space.
13. Where appropriate, if the chipper is detached from the tow vehicle, apply the handbrake and, if necessary, chock the wheels.
14. On all reasonably foreseeable approaches to the worksite, erect warning and prohibition signs conforming to the Health and Safety (Safety Signs and Signals) Regulations 1996, indicating a hazardous worksite and that unauthorised access is prohibited. In areas of very high public access, a risk assessment may indicate that additional controls (e.g. barrier tape, barriers, extra manning) are required.
15. Ensure all operations near to highways are adequately signed with the appropriate notices as specified in the DTLR Code of Practice *Safety at street works and road works* (available from The Stationary Office ISBN 0 11 551958 -0)
16. Ensure that the discharge chute is positioned to prevent chips being blown onto the highway during roadside operations, or in any direction where they

can affect colleagues or members of the public.

17. Position the chipper so that operators do not have to stand on embankments/slopes when feeding material into the machine

### **EMERGENCY PROCEDURES**

18. Ensure a designated and responsible person knows the daily work programme and agree with them a suitable emergency contact procedure. Where reasonably practicable use a mobile phone or radio and pre-arrange call-in system.
19. Ensure the operators can provide the emergency services with enough detail for them to be found in the event of an accident, e.g. the grid reference, the distance from the main road, the type of access (suitable for car/four-wheel drive/emergency service vehicles). In urban areas street names are essential. Know the location details before they are needed in an emergency. (Also see AFAG leaflet 802 *Emergency planning*)

### **OPERATION**

20. Make sure the cuffs of gloves are close fitting or tucked into you're sleeves to stop them being caught on material as it is fed into the chipper.
21. Set the engine speed (and set the stress control if fitted) to obtain optimum performance.
22. Check that material to be chipped is free from stones, metal and foreign objects.
23. Stand to one side of the infeed rollers to avoid being hit by ejected material.
24. Let material go as soon as it is engaged in the infeed rollers or chipping components.

## Maintenance

25. Use a push stick at least 1.5 metre long, for both short produce and for the last piece of produce to be chipped.
26. Do not put any part of your body (including hands or feet), into the infeed hopper while the machine is running.
27. Always follow the manufactures' instructions for dealing with blockages on the machine.
28. Keep the area of ground in front of the infeed hopper free from debris to prevent any tripping hazard.
29. Remove the engine start key when the machine is left unattended or when undertaking any maintenance.

## FUELLING

30. Stop engine and, if necessary allow the machine to cool before refuelling.
31. Petrol vapour is invisible and can flow considerable distances from spillage or fuelling sites. Maintain a safe distance from any source of ignition at all times.
32. Store fuel to avoid vapour ignition from any source such as fires, people smoking or the wood chipper. Select a site shaded from direct sunlight and away from watercourses and drains.
33. Containers must be clearly labelled and have securely fitting caps. Plastic containers must be designed and approved for use with petrol or diesel fuel.
34. Replace the fuel cap securely.
35. Keep fuel from contacting the skin. If fuel gets into the eyes wash out with sterile water immediately and seek medical advise

36. Ensure the machine is carried out in accordance with the manufacture's handbook.
37. Check chipping components and knives each day for damage and wear.
38. Wear gloves when handling knives.
39. Before working on knives, confirm that the engine is switched off, the start key removed, and the chipping component is stationary.
40. Before opening any guard/cover or reaching into the infeed hopper or discharge chutes make sure that the engine is switched off, start key removed and dangerous parts have come to a stand still.
41. Knives must be changed or reversed if damaged or blunt. Knives must be scrapped when worn to the minimum size specified by the manufacturer.
42. When new/sharpened knives are fitted, ensure that there is the recommended clearance between the knives and the anvil.

## MOVING THE MACHINE

43. Stop the engine and remove the start/stop key.
44. Lock the chipping components.
45. Secure the infeed hopper and the chip discharge chute in the transport position.
46. Check the towing bracket, attach, then lift and secure the jockey wheel.
47. Connect the electrics and the safety chain/s to the towing vehicle.

48. Ensure that the load is secure and that people are in a safe position before moving off.

For further leaflets and reading see HSE web site:

[www.hse.gov.uk](http://www.hse.gov.uk)

### **Further HSE Reading**

Mechanical roadside processing AFAG605

Emergency planning AFAG802

Training and certification AFAG805

First aid at work:

Your questions answered INDG214

Managing health and safety

In forestry INDG294

Protect your hearing or lose it! INDG363

### Further reading Continued

Power-fed mobile wood chippers:

Operator protection at infeed chute AIS38

Power take-offs and power take-off  
drive shafts AS24