

EcoTMP

Tractor mounted Chipper



Operator's Manual

SECTION:**1. Introduction and Purpose****2. Technical Specifications, Dimensions, Noise Level, and Lifting points****3. Safety and Symbols**

- 3.1 Ensure!
- 3.2 Never!
- 3.3 Always!
- 3.4 Safety controls and switches
- 3.5 Control cut-outs (*not applicable*)
- 3.6 'No Stress' system
- 3.7 Symbols

4. Machine Preparation

- 4.1 Fitting to tractor
- 4.2 Infeed chute
- 4.3 Discharge chute
- 4.4 PTO (Power take off) Shaft length

5. Operation

- 5.1 Pre-work checks
- 5.2 Starting machine
- 5.3 Stopping machine
- 5.4 Adjustable Feed roller control
- 5.5 Operating Hints
- 5.6 Preparing for Transport on completion of work

6. Maintenance

- 6.1 Routine Maintenance schedule and lubrication points
- 6.2 Drive Belts
- 6.3 Drive Belt Tension
- 6.4 Hydraulic Connections
- 6.5 Steam Cleaning
- 6.6 Bearings and Pivots
- 6.7 Disc blades
- 6.8 Gearbox
- 6.9 Electrical Connections
- 6.10 Mountings
- 6.11 No Stress system
- 6.12 Fault finding chart
- 6.13 Blade sharpening

7. Storage**7.1 Storage****7.2 Removal from storage****8. Disposal****9. Appendix****9.1 Hydraulic Circuit****9.2 Electrical Circuits****9.3 Certificate of Conformity****9.4 Risk Assessment****9.5 Noise Assessment****9.6 Parts List****9.7 Transcript of HSE leaflet 604**

INTRODUCTION

This manual explains the proper operation of your machine. Read these instructions thoroughly before operating and maintaining the machine. Failure to do so could result in personal injury or equipment damage. Consult your GreenMech supplier if you do not understand the instructions in this manual.



CAUTION! This symbol indicates important safety messages in this manual. When you see this symbol, be alert to the possibility of injury to yourself or others, and carefully read the message that follows.

We recommend that you keep this manual with the machine in the box provided. Note here the serial number and quote it in any communications. This is important when ordering spares. Remember to include all numbers and letters.

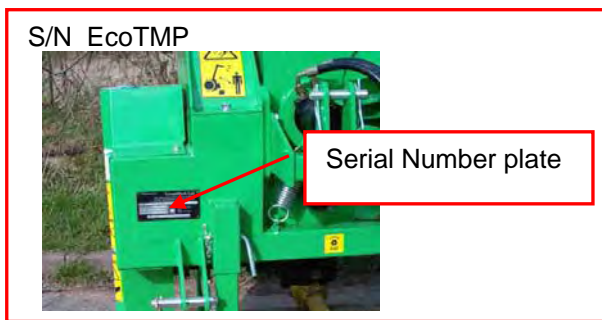

VIN Number:.....

Serial Number:.....

Write in the number!

This manual covers the following model.

EcoTMP tractor mounted chipper

Note: Normal build infeed chute position is Left Hand side (nearside) of tractor. This can be changed to Right Hand side by factory fitted reversal of the gearbox.

The information in this manual is correct at the time of publication. However, in the course of development, changes to the machine specification are inevitable. Should you find any information to vary from the machine in your possession please contact your GreenMech dealer for up to date information.

The manual may contain standard and optional features and is not to be used as a machine specification.

PURPOSE



CAUTION! This machine is designed solely to chip wood and must not be used for any other purpose. The machine should only be used by trained operators who are familiar with the content of this instruction manual. It is potentially hazardous to fit or use any parts other than genuine GreenMech parts. GreenMech Ltd disclaims all liability for the consequences of such use, which in addition voids the machine warranty.

Fig 2.1 EcoTMP Main Features

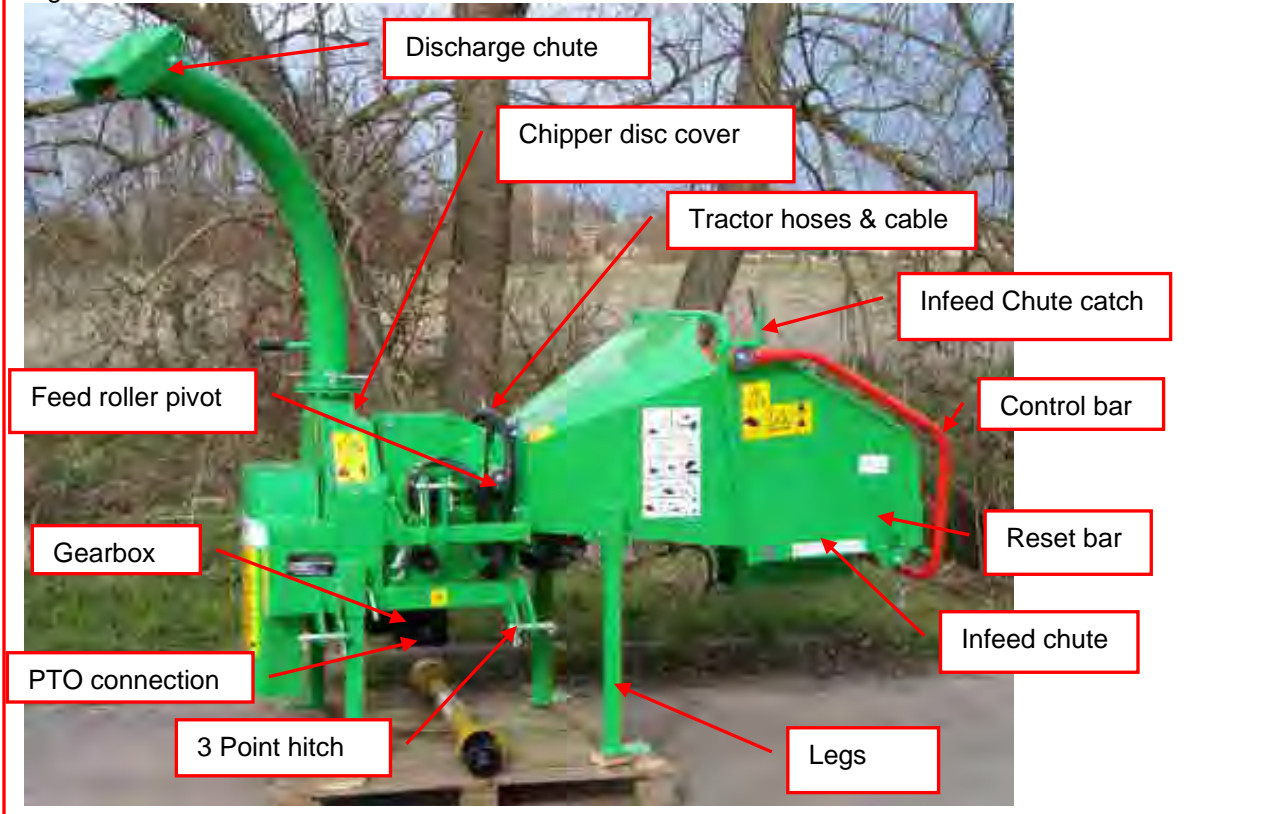

| TECHNICAL SPECIFICATION EcoTMP | |
|--------------------------------|---|
| Max Capacity | 150mm (6-inches) |
| Chipping Disc | 500mm x 25mm (19.86 x 1.01inch) |
| Speed | 2600 rpm |
| Chipping Blades | 2 Discs |
| Feed Rollers | 2 x Hydraulic |
| Power Control | No-Stress Electronic Feed Roller Controller |
| Power Unit | Tractor 25-45hp (see below) |
| Length (Transport) | 2320mm |
| Width | 1060mm |
| Height | 2130mm |
| Weight | 487Kg |

Noise

Noise levels vary depending on type of material being processed. Also duration of operation is variable. Noise emission tests have been carried out and the guaranteed sound power level is displayed on the CE plate as follows: **Lwa 120dba**

Minimise noise by switching to idle or stopping the tractor engine whenever chipping is not in progress.

On tractors having optional 1000rpm PTO speed, this can be selected but the engine speed must be reduced to avoid exceeding 540rpm and 40hp maximum power.



CAUTION! Do not operate above 540rpm.

Full details are included in the Risk Assessment in the Appendix.



CAUTION! Operators must wear appropriate ear protection. Bystanders must be kept away from proximity of machine.

Lifting Points

There are three lifting points by the chipper disc cover.

Tractor requirement

25 – 40HP at 6 spline 540rpm PTO shaft with provision for 22 litres/min (4.8 gall/min) at 172 bar (2500 lbf/in²) continuous flow remote oil supply and trailer light socket for No Stress system.

**3.1 ENSURE:**

- 3.1.1 All Operators must be fully trained in the use of their machine.
(*Certificated Operator training courses are available on request.*)
- 3.1.2 The Operators Manual is read and understood.
- 3.1.3 The enclosed HSE guidance notes are read and understood.
- 3.1.4 The machine is positioned on level ground and the machine must be level with the infeed chute at no less than 600mm (23.62 inches) above ground level (fig 3.4.3).
- 3.1.5 *not applicable*
- 3.1.6 All guards are fitted and in good condition.
- 3.1.7 Blades are in good condition and secure.
- 3.1.8 All blades are sharpened or replaced in "Sets".
- 3.1.9 All fasteners are checked regularly for tightness.
- 3.1.10 Only "WOODEN" materials free of nails etc., are fed into the machine.
- 3.1.11 Correct First Aid Kit including large wound dressing is available on site.
- 3.1.12 Fire extinguisher is available on site.

**3.2 NEVER:**

- 3.2.1 Work on the machine until the chipper disc is stationary and engine or PTO has stopped.
- 3.2.2 Operate the machine without protective clothing (Eye protection, Earmuffs, and Gloves), or high visibility clothing when working on roadside.
- 3.2.3 Operate with loose articles of clothing, including loose cuffs on gloves.
- 3.2.4 Work under a raised component without adequate safety support.

- 3.2.5 Operate the machine with untrained personnel or with individuals present who are not involved in the chipping operation.
- 3.2.6 Leave the machine unattended with engine running at full operating speed.
(See section 4)

- 3.2.7 Put any part of your body into the infeed chute while the machine is running.
- 3.2.8 Operate the machine whilst under the influence of alcohol or drugs.
- 3.2.9 Operate inside a building or confined space.
- 3.2.10 Climb on the infeed chute.

**3.3 ALWAYS:**

- 3.3.1 Check machine before starting (see Section 4 Preparation and Section 5.1 Operation: Pre-work checks).
- 3.3.2 Be aware of potential hazards in the work area, i.e. uneven ground, tree roots, trip/slip hazards, obstructions and type of materials being fed into the machine.
- 3.3.3 Feed from the side.
- 3.3.4 Have a second trained operator within easy reach of the machine.
- 3.3.5 Maintain strict discipline at all times.
- 3.3.6 Service machine at specified periods. (see Section 6: Routine Maintenance).
- 3.3.7 Note direction of discharge chute and if necessary note the wind direction to prevent debris from being blown into highway or where it could affect members of the public.
- 3.3.8 Remove key before doing any maintenance.

Fig 3.4.1 Control Bar and Reset Lever

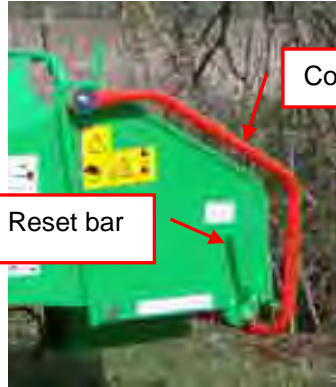

Control bar

Reset bar

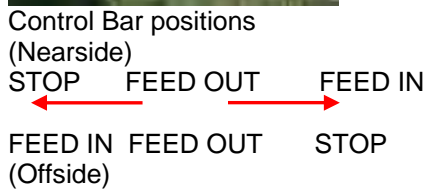

3.4 Safety Controls and Switches

3.4.1 Emergency Stop/Control Bar (fig 3.4.1)

In the event of an emergency, push the emergency stop bar to STOP the feed rollers. This will lock in position.

3.4.1.1 Once the emergency has been rectified the following sequence should be carried out:

3.4.1.2 To restart rollers pull the reset lever, the control bar can then be returned to the Feed In position.

3.4.1.3 Should the stop bar be tripped accidentally in normal working conditions i.e. NOT an emergency, then the rollers can be recovered by performing the above sequence.

3.4.1.4 To reverse the rollers (feed out) push the control bar into the middle detent. To regain forward (feed in) pull the control bar away from the chipper. It is not necessary to use the reset bar.

3.4.2 PTO stop

3.4.2.1 To stop the PTO use the tractor control or tractor engine stop.

⚠ CAUTION! Do not restart until hazard has been removed.

3.5 Control cut-outs

Not applicable for tractor mounted model

3.6 No Stress system

3.6.1 Speed sensor disables feed roller FEED IN or FEED OUT mode when engine speed is below factory pre-set value.

Fig 3.4.3 Infeed chute height



Infeed chute height 600mm min. (24")

3.7 SYMBOLS on the MACHINE

These relate to operator safety, correct use and maintenance of machine. Check that all personnel understand and are familiar with meanings before using the machine.

Important Safety symbols

Take the correct action shown on the display below the stated hazard (see table)



| | | | | | |
|------------------------------|-----------------------------|-----------------------------------|------------------------------|----------------------------|-----------------|
| Caution! | | Remove key | | Do NOT start engine | |
| Caution! | Beware flying object hazard | Beware noise hazard | Beware trapping hazard | Brakes off -incorrect | |
| Read instruction manual | Wear helmet & visor | Wear ear protectors | Wear proper clothes | Brakes on -correct | |
| | | | | | |
| Machine not level -incorrect | Beware flying object hazard | Beware flying object hazard | Beware exposed drives hazard | | Caution! |
| Machine level -correct | Keep bystanders away | Position and lock discharge chute | Fit all guards | Keep nuts tight | |

Important Operating Checks Notice

Before use carry out daily the stated checks in the order shown (see table)

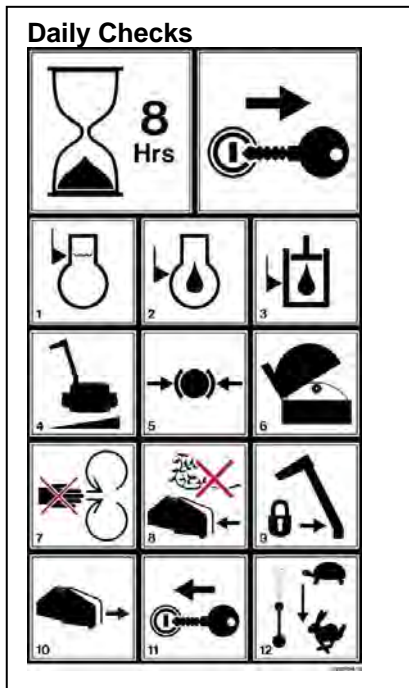

| | | | |
|---------------------------------------|--|--|--|
| Every 8 Hours – Daily checks | | Remove key stop engine | |
| 1. Check coolant level | 2. Check engine oil level | 3. Check hydraulic oil level | |
| 4. Check machine is level | 5. Check brakes are on | 6. Check chipper disc is clear of debris | |
| 7. Check all guards are in place | 8. Check infeed chute is clear of debris | 9. Lock discharge chute | |
| 10. Pull control bar to work position | 11. Start engine | 12. Increase from Idle to Run | |

Important Safety Information

Caution! Beware of thrown object hazard



Action: Keepaway from fast discharge chute

Caution! Beware of thrown object hazard



Action: Stand to side of infeed chute, NOT in centre.

Caution!



Do NOT operate with infeed chute at less than 600mm from ground (bottom bar machine).

Sound level



Ear defenders must be worn

Transport Lock



Lock this component before moving machine

Lift Point

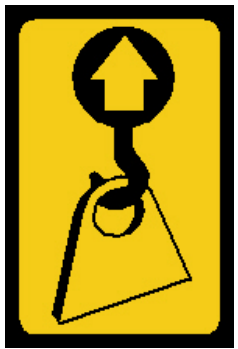

PTO Direction



Maintenance Information



Operating Information

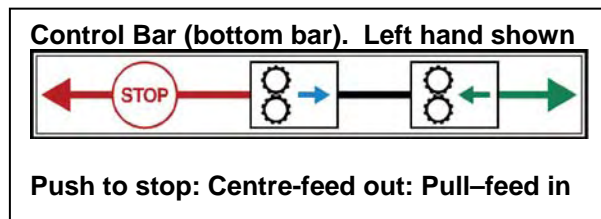
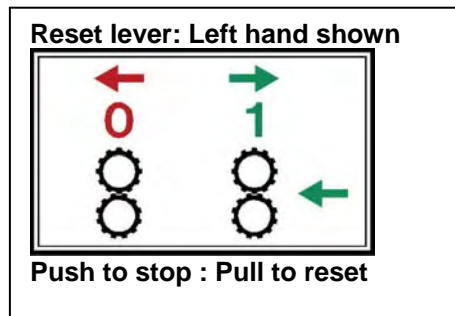
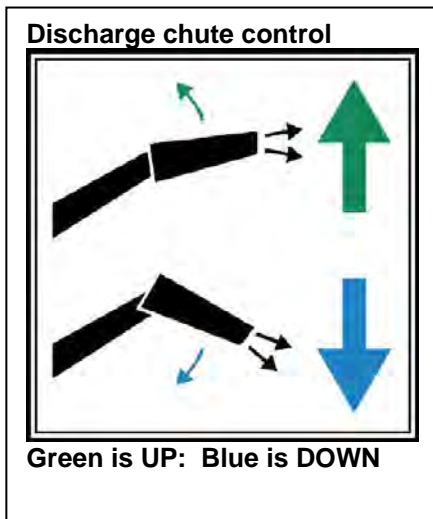

Fig 4.1.1 3 Point links and PTO shaft

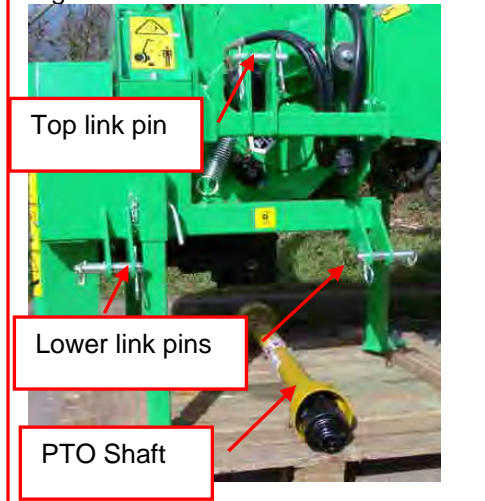
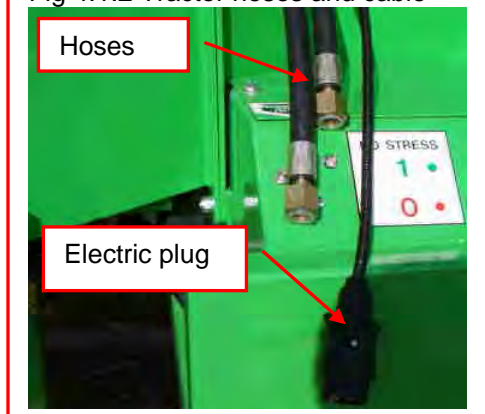

Fig 4.1.2 Tractor hoses and cable



4.1 Fitting to tractor

4.1.1 Remove the top, and lower linkage pins on the chipper (fig 4.1.1)

4.1.2 Lower the three-point linkage on the tractor and reverse up to the chipper.

4.1.3 Locate the two lower linkage pins through the lower arms and the chipper frame.

4.1.4 Secure the pins with the clips provided.

4.1.5 Adjust the top link to the correct length and locate the linkage pin through the frame and arm, secure with the clips provided.

4.1.6 Switch off the tractor engine.

4.1.7 Check that the PTO shaft is the correct length for the tractor make and model. See section 4.4 below

⚠ CAUTION! The PTO shaft is equipped with shear bolt protection and this end of the shaft **MUST** be fitted to the tractor PTO shaft. (Pictograms stamped on PTO shaft cover may be incorrect.)

4.1.8 Depress the two spring buttons and slide onto the tractor shaft until the buttons spring out into the correct locations.

4.1.9 Depress the single spring button on the ratchet clutch end and slide onto the chipper gearbox shaft until the button springs out into the correct location.

4.1.10 Connect up the hoses to the tractor remote supply. (fig 4.1.2)

4.1.11 Connect the cable to the trailer socket on the tractor.

4.1.12 Turn on the tractor's sidelights to provide power for the No-Stress system.

⚠ CAUTION! Check that the discharge chute does not hit the tractor cab when the chipper is lifted up.

⚠ CAUTION! Do not operate the machine when not fully attached to the tractor

4.1.13 Unfold infeed chute as 4.2 below.

4.1.14 Start tractor engine slowly and check PTO. operation.

Fig 4.2 Infeed chute catch

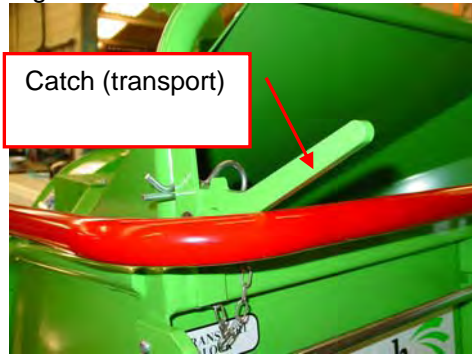

4.2 Infeed Chute

4.2.1 Remove the transport pin for the infeed chute catch, release the catch (fig 4.2)

4.2.2 Using the tubular edge as a handle, lower the infeed chute to the work position and reset the catch.

4.2.3 Measure the height of the infeed chute and adjust stands as required.

4.2.4 Pull the reset lever to release the control bar for use.

⚠ CAUTION! The infeed chute must not be used at less than 600mm from the ground. (fig 3.4.2).

⚠ CAUTION! Before travelling, always fold up and secure the infeed chute.

4.3 Discharge Chute (Fig 4.4)

4.3.1 Release the swivel clamps, point the chute in the desired direction and tighten the clamps.

4.3.2 Set the flap at the desired height and tighten the clamp.

⚠ CAUTION! Lock the discharge chute in the rearward position when travelling.

Fig 4.3 Discharge Chute



4.4 PTO shaft length

The PTO shaft must overlap by 150mm in longest situation and not bottom out in shortest situation. Always follow instructions supplied with shaft if available.

4.4.1 To shorten PTO, separate each section and refit to machine.

4.4.2 Raise machine on linkage until shortest length is achieved.

4.4.3 Supporting the two sections side by side, mark a point 25mm - 50mm back from where the guard tube meets the joint guard onto the other section. Repeat for the opposite end.

4.4.4 Adjust the tractor linkage to set at longest shaft length.

4.4.5 Check that 150mm minimum overlap of sections is achieved between marks.

4.4.6 Saw off the surplus guard and shaft at each mark and remove cuttings and burrs.

4.4.7 Grease the shaft, reassemble to machine, and test before use.

Fig 5.1.1 Support Legs

Support Legs (4)

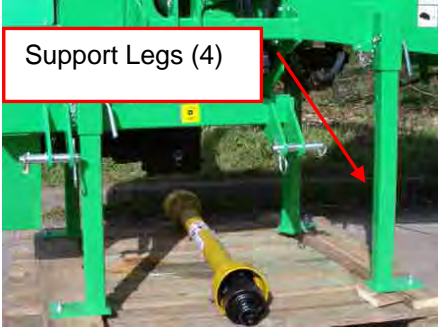

Fig 5.1.2 Chipper Disc Cover

Disc Cover
locating bolt

5.1 Pre-Work Checks:

5.1.1 Check tractor is stationary, engine turned off and hand brake applied.

5.1.2 With machine held on tractor linkage, set support legs approximately (fig 5.1.1).

5.1.3 Lower linkage, check that machine is level and infeed chute is greater than 600mm from ground (fig 3.4.3).

5.1.4 Check fasteners for tightness and hydraulic connections for leaks.

5.1.5 Check condition of disc blades.

5.1.5.1 Check nothing is rotating.

5.1.5.2 Remove the 1 bolt retaining chipper disc cover (fig 5.1.2).

5.1.5.3 Using discharge chute handle as a lever, swing back cover on to stop to expose chipper disc and blades.

(fig 5.1.2)

5.1.5.4 Carefully rotate chipper disc to check tightness of disc blade bolts and condition of blades.

5.1.5.5 Remove any loose wood material.

5.1.5.6 If any bolts are loose, refer to maintenance section for further action.

5.1.5.7 Replace chipper disc cover and tighten bolts securely.

5.1.6 Check discharge chute is in desired position and all clamps are tight. (see Section 4.3)

5.1.7 Check infeed chute flap is lowered.

5.1.8 Check work area and erect signs and cone off discharge area if necessary.

5.1.8 Check **ALL** safety procedures have been followed.



CAUTION! Remember to raise infeed chute flap and the chipper on the tractor linkage before driving off.

Fig 5.4 Adjustable feed roller control



Control knob settings

| Material | Setting |
|-------------|----------------------|
| up to 120mm | Fully open (3 turns) |
| 120 - 150mm | 1/2 to 3/4 turn |

5.2 Starting Machine:

- 5.2.1 Check all other personnel are clear of machine.
- 5.2.2 Check that feed roller control bar is pushed to the FEED OUT or STOP position, to make the machine safe.
- 5.2.3 Start the tractor.
- 5.2.4 Engage PTO to start the chipper. Check lights are ON.
- 5.2.5 Increase the speed to operating speed (PTO 540 rpm), when No Stress light goes Green.

Note: When used with larger tractors having 1000 rpm PTO option, this may be selected to enable use of slower engine speed to reduce noise level and fuel consumption. Always ensure that the No Stress light remains Green.

- 5.2.6 Pull the reset lever to release the control bar for work.

5.3 Stopping Machine

- 5.3.1 Push the control bar to STOP position.
- 5.3.2 Disengage tractor PTO.
- 5.3.3 Stop tractor engine.
- 5.3.4 Wait for chipper disc to stop.



CAUTION! The chipper disc will take several seconds to stop due to its inertia.

5.4 Adjustable Speed Feed Roller Control

When chipping wood sizes larger than 120mm diameter it may be necessary to reduce the feed roller speed to suit the material being chipped.

- 5.4.1 Turn the valve control knob (fig 5.4) clockwise until valve is closed.
- 5.4.2 Turn the knob anticlockwise to the recommended setting in the table.

5.5.1 Check that chipper disc is at full speed with NO Stress light Green.

NOTE: The “No Stress” system will only allow FEED IN (Forwards) and FEED OUT operation of the feed rollers when the machine is running at FULL operating speed.

5.5.2 Reduce the chipper speed to IDLE whilst further material is collected for chipping.

5.5.3 Take care when feeding wood into the machine to allow for awkward shapes to “KICK” when contacting the feed rollers.

5.5.4 Position the end of larger sections of wood inside the infeed chute and then support the other end whilst pushing the wood into the feed rollers.

⚠ CAUTION! Do not release discharge chute clamps when chipping is in progress. Elevation of the discharge is altered by means of the adjustable flap (fig. 4.4).

⚠ CAUTION! Keep working area around the machine clear at all times and check only authorised personnel are present.

Fig 5.6 Chutes ready for transport (except legs)



5.6 Preparing For Transport On Completion Of Work (fig 5.6)

5.6.1 Check that engine has stopped and chipper disc is stationary.

5.6.2 Remove surplus material from infeed chute and machine surfaces.

5.6.3 Lift up infeed chute to transport position, secure with lock and fit locking pin.

5.6.4 Set discharge flap into lowest position and tighten clamp.

5.6.5 Release clamps, turn discharge chute to rearward position away from cab, tighten clamps.

5.6.6 Raise machine on tractor linkage.

5.6.7 Raise support legs and secure if transporting on rough terrain.

5.5 Operating Hints

ROUTINE MAINTENANCE SCHEDULE

 **CAUTION!** Always stop tractor, remove key and check for rotation before carrying out any maintenance.

| Action | Section | Page |
|--|---------|------|
| DAILY | | |
| Check drive belt | 6.2 | 6-3 |
| Check condition of disc blades and retaining bolts | 6.7 | 6-4 |
| Check feed roller control bar function | 3.4 | 3-2 |

| | | |
|--|------|-----|
| First 50 hours | | |
| Check drive belt tension | 6.3 | 6-3 |
| Check hydraulic connections | 6.4 | 6-3 |
| Check all mountings | 6.10 | 6-5 |
| Check feed roller control bar function | 3.4 | 3-2 |

| | | |
|--|--------------------------------|-----|
| Weekly in addition to Daily actions | | |
| Check drive belt tension | 6.3 | 6-3 |
| Steam clean machine | 6.5 | 6-3 |
| Check electrical connections | 6.9 | 6-5 |
| Check feed roller control bar function | 3.4 | 3-2 |
| Grease all bearings and pivots | 6.6, 6.1 | 6-3 |
| Check hydraulic connections | 6.4 | 6-3 |
| Check gearbox oil level | 6.8 | 6-5 |
| Check PTO shaft | Refer to supplier instructions | |
| Check all mountings | 6.10 | 6-5 |

| | | |
|--|-----|-----|
| 250 hours in addition to Daily and Weekly actions | | |
| Check condition of bearings and pivots | 6.6 | 6-3 |

| | | |
|---|-----|-----|
| 1000 hours in addition to 250 hour actions | | |
| Drain gearbox oil | 6.8 | 6-5 |

| Recommended lubricants | Specification |
|------------------------|---------------------------------------|
| Gearbox Oil | EP90 |
| Grease | Complex grease EP2 (high temperature) |

Fig 6.1 Lubrication points EcoTMP

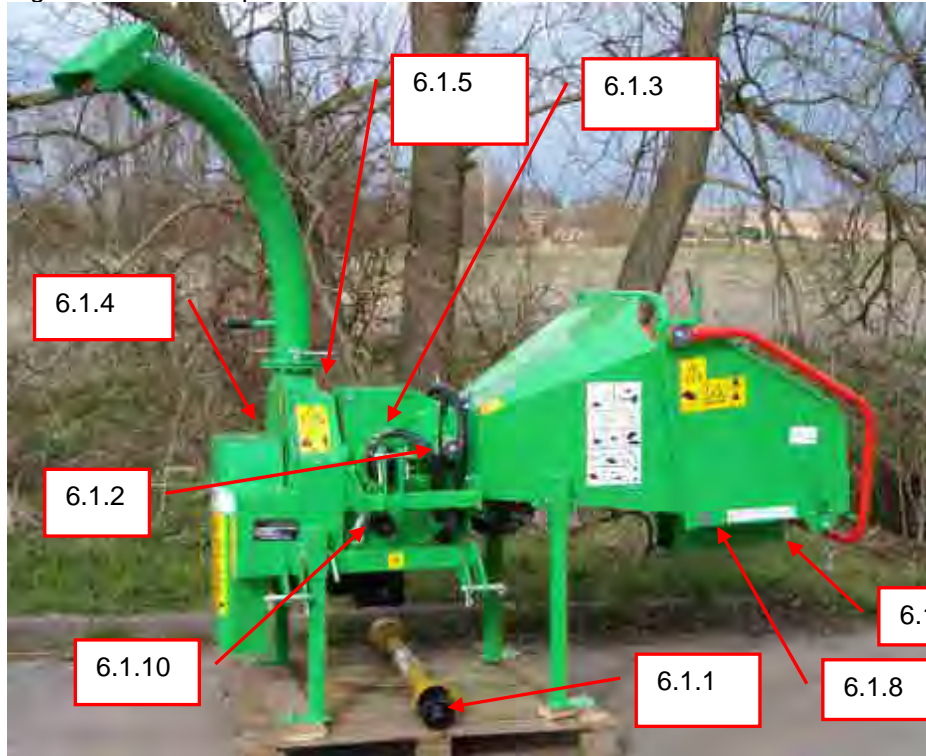

6.1 Lubrication Points (see 6.14)

Grease except where stated

| | | |
|--------|----------------------------|------------------|
| 6.1.1 | PTO shaft | 2 nipples |
| 6.1.2 | Top Feed roller pivot | 1 nipple |
| 6.1.3 | Top Feed roller bearing | 1 nipple |
| 6.1.4 | Chipper Disc front bearing | 1 nipple |
| 6.1.5 | Chipper Disc rear bearing | 1 nipple |
| 6.1.6 | Labyrinth seal | 1 nipple |
| 6.1.8 | Infeed chute hinges | Oil |
| 6.1.9 | Mechanical reset mechanism | Clean and grease |
| 6.1.10 | Bottom Feed roller bearing | 1 nipple |

Note. Do not overgrease bearings as damage to seals may occur.

Note: Use high temperature grease on chipper disc bearings.

Fig 6.1.2 Grease nipples (Opposite side)

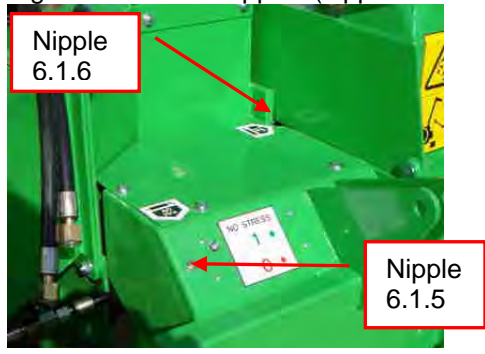

Fig. 6.2 Drive Belt Guard



6.2 Drive Belts

6.2.1 Remove belt guard (fig 6.2) and check belts daily, before work.

6.2.2 Replace Guard before use.

6.3 Drive Belt Tension

The belt is tensioned by a screw under the machine to set the gearbox mounting (fig 6.3).

6.3.1 Loosen nut and adjust bolt to tension belts.

6.3.2 Tighten nut.

Fig. 6.3 Belt Tensioner

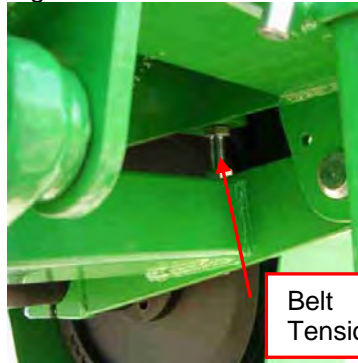

6.4 Hydraulic connections

50 hours

6.4.1 With the aid of the circuit diagram to follow the hose routings, check all hoses and connections for leaks and damage.

6.4.2 Replace any worn or damaged hoses with the correct type and length.

6.4.3 Before removal, check routing and ensure replacement hose is fitted free of strains, twists or kinks.



CAUTION! Ensure any residual pressure is released before dismantling.



CAUTION! Ensure hoses are refitted free of twists and kinks.

6.5 Steam Cleaning

weekly and every 250 hours

6.5.1 Check all covers are fitted and closed

6.5.2 Steam clean machine surfaces.

6.5.3 Clean electrical components with a damp rag, spray with WD40 and then wipe with dry rag.



CAUTION! Do not steam clean directly on to electrical components, e.g. control boxes.

6.6 Bearings and Pivots

Weekly

See paragraph 6.1 for routine lubrication.

250 hours

6.6.1 Check rotating components for excessive movement and noise in operation.

6.6.2 Replace as required.

Fig 6.5 Disc Cover



6.7 Disc Blade Rotation and Replacement

The design of the blades permits relocation in at least three rotated positions before regrinding or replacement is required.

6.7.1 Check tractor engine is switched off and start key removed.

6.7.3 Remove the bolt retaining chipper disc cover (fig 6.7.1).

⚠ CAUTION! Take care. Blades are extremely sharp.

6.7.4 Using discharge chute handle as a lever, swing back cover on to stop to expose chipper disc and blades.

6.7.6 Current best practice is to 'lock' chipper disc with timber or similar in desired position when slackening or tightening disc blade retaining bolts to 150NM

6.7.7 Slacken disc blade retaining bolt, remove disc, clean mounting face and location (fig 6.7.2).

6.7.8 Replace disc in a rotated position to present a sharp section to the shear bars.

6.7.9 Torque up bolt to 150NM (110lb.ft.)

6.7.10 Check condition and security of shear bars. Rotate or replace if required. Do not regrind.

⚠ CAUTION! Disc blades must only be sharpened by grinding the angled back face on a bench grinder. Grinding of the front face will upset the gap, which is factory set. Do not sharpen with hand held equipment.

Note. If any of the Disc-Blades are worn below the flat annular section a complete set should be replaced. Inspect condition of nuts and bolts and replace if any signs of wear.

All blades must be sharpened in "sets" with equal amounts removed to maintain balance. (See section 6.13 for disc regrinding.)

Fig 6.7.2 Chipper disc and blades

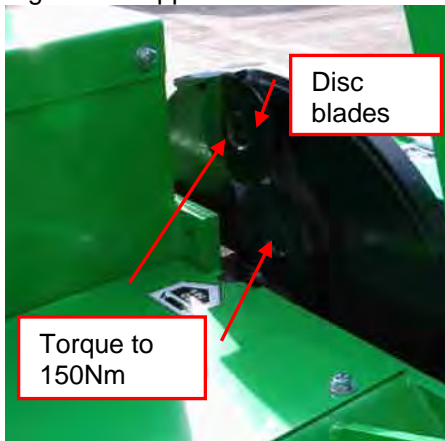
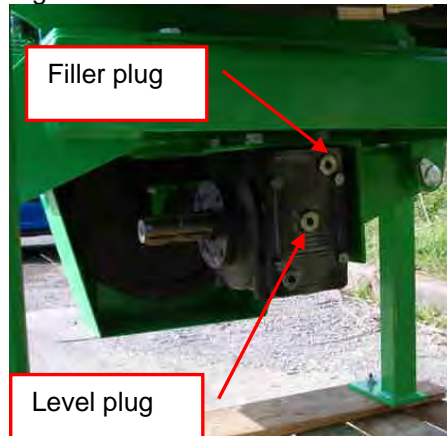

Fig 6.8 Gearbox

**6.8 Gearbox****Weekly**

6.8.1 Check level and refill as required.

1000 Hours

6.8.2 Drain and refill with clean oil.

6.9 Electrical connections**weekly**

6.9.1 Check all wiring loom connections are secure.

⚠ CAUTION! Poor connections will affect performance of No Stress.

6.10 Mountings**250 hours**

6.10.1 Check that all mounting bolts are tight.

⚠ CAUTION! Do not overtighten.

Fig 6.11 No Stress Isolator

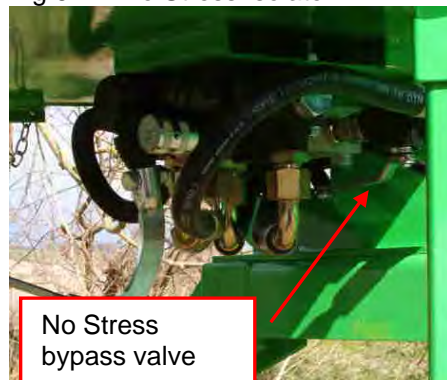
**6.11 No Stress system**

Note The engine operating speeds for the No Stress system are factory set for particular machine builds and must not be readjusted.

The No Stress system may be bypassed with the hand valve (fig 6.11)

6.12 Fault finding

| Fault | Check | Action | Page |
|-----------------------------|-------------------------|----------------------|------|
| Engine not at correct speed | Tractor engine control | Check operation | 5-2 |
| Blade disc will not start | Drive belts | Replace | 6-6 |
| Feed rollers do not turn | Control bar | Reset and check | 3-2 |
| | Hydraulics | Check solenoid valve | |
| Feed will not reverse | Control bar | Reset and check | 3-2 |
| | Hydraulic valve | Check operation | |
| Discharge does not flow | Discharge chute | Check for blockage | 4-2 |
| | Blade disc | Check for blockage | 5-1 |
| Unusual noise(s) | Blade disc and bearings | Check and replace | 5-1 |

6.13 Chipper Disc Re-grinding

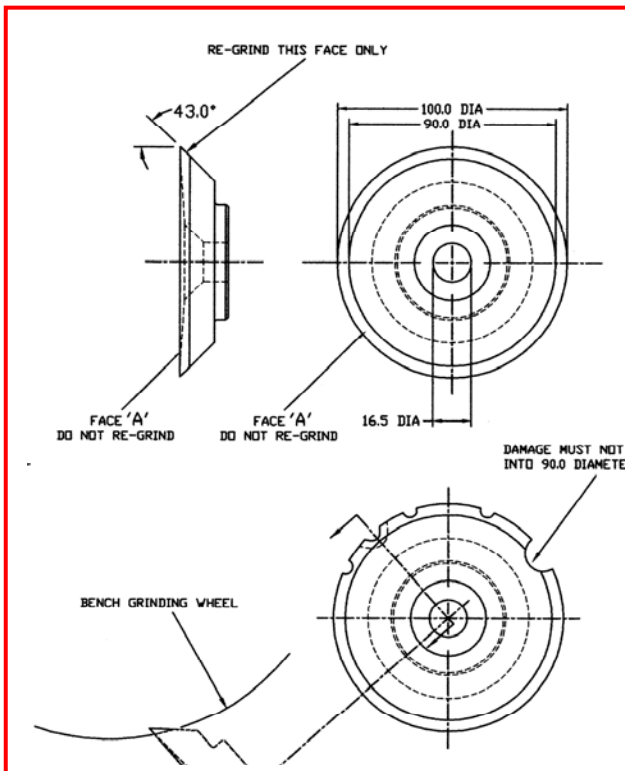

6.13.1 Examine set of chipper discs for damage. If front face 'A' is worn the disc must be scrapped. If chips have broken off the cutting edge they can be re-dressed provided that they do not go inside the 90mm diameter.

6.13.2 Always regrind the worst damaged disc first, as this will establish the target weight for the other discs.

6.13.3 If large chips exist over less than 30% of the circumference the disc may be re-ground provided the large damaged area is not used for chipping.

6.13.4 Chips may be repaired by grinding a cutting edge around the damaged area using a bench grinder.

6.13.5 With chipper disc mounted on a mandrel re-grind remainder of cutting edge at 43° as shown

6.13.6 Re-grind in increments of approximately 0.01mm (0.004") until sharp edge is restored.

6.13.7 If re-grinding breaks into the 90mm diameter the disc must be scrapped.

6.13.8 After re-grinding the weight of discs within a set must not vary by more than +/- 1gm (0.03oz). The weight of each disc must not be less than 560gm (20oz)

7.1 Storage

- 7.1.1 Thoroughly clean machine and note any replacement parts required.
- 7.1.2 Carry out 250 hour service if not already done. Refer to Section 6
- 7.1.3 Fit replacement parts when available.

7.2 Removal from Storage

- 7.2.1 Carry out machine preparation as necessary Refer to Section 4

When the machine is finally scrapped, the following items should be disposed of only at authorised waste disposal facilities.

Gearbox oil. Hydraulic oil.

If in doubt, consult the Local Authority environmental department.

Major non-ferrous items such as hydraulic hoses may also be disposed of separately.

**Safety Guides and Checklist as
Transcribed from and Advised by
Arborculture & Forestry Advisory Group
and Issued as Leaflet 604 by HSE, issued
04/03**

INTRODUCTION

This leaflet covers the safe working practices to be followed when operating a wood chipper.

It does not cover a combination of machines working within each other's risk zones (see AFAG leaflet 605 *Mechanical roadside processing*)

You can use this leaflet, along with the manufacturer's handbook, as part of the risk assessment process to help identify the controls to put in place when using a wood chipper.

You must also assess the effect of the site and the weather as well as following this guidance

All operators must have had appropriate training in how to operate the machine and how to carry out the tasks require (see AFAG leaflet 805 *Training and certification*)

PERSONAL PROTECTIVE EQUIPMENT (PPE)

1. Use the following PPE
 - A Safety Helmet, complying with EN 397, if identified as required in the risk assessment.
 - Eye Protection (a mesh visor complying with EN1731 or safety glasses to EN166)
 - Hearing protection (complying with EN352) where noise level exceeds 85 dB(A) (see HSE pocket card INDG363 *Protect your hearing or lose it!*)
 - Gloves.

- Safety Boots with good grip and ankle support (complying with EN345-1)
- Non-Snag Outer Clothing appropriate to prevailing weather conditions. High-visibility clothing (complying with EN471) should be worn when the risk assessment identifies that it is needed.

2. Each person should carry a personal first-aid kit including a large wound dressing (see HSE leaflet INDG214 *first aid at work; Your questions answered*).
3. Hand cleaning material such as waterless skin cleanser or soap, water and paper towel should be readily available.

THE MACHINE

4. Before working with a machine, check it has been properly converted from any transport mode.
5. Ensure guards for dangerous parts (e.g. belts, pulleys, shafts etc) are secure and undamaged.
6. Ensure protective devices, such as the infeed control bar (incorporating the stopping device), are working correctly (see HSE leaflet AI S 38 *Power-fed mobile wood chippers: Operator protection at infeed chutes*).
7. Ensure any lock for the chipping components has been disengaged;
8. Ensure the infeed hopper is clear of any materials.
9. Ensure Noise warning signs are in place.
10. For machines driven by a power take-off (PTO) shaft, before starting ensure:

- The PTO shaft is fitted with a suitable guard complying with EN1152, that encloses the shaft along its full length from tractor to machine.
- The guard is correctly fitted and in effective working order (see AS24(rev) ***Power take-offs and power take-off drive shafts***);
- The PTO speed is suitable for the machine.

SELECTING THE WORK AREA

11. Select as firm a surface as possible and stabilise the machine
12. Ensure ventilation is adequate and any exhaust fumes are vented into open air if working in an enclosed space.
13. Where appropriate, if the chipper is detached from the tow vehicle, apply the handbrake and, if necessary, chock the wheels.
14. On all reasonably foreseeable approaches to the worksite, erect warning and prohibition signs conforming to the Health and Safety (Safety Signs and Signals) Regulations 1996, indicating a hazardous worksite and that unauthorised access is prohibited. In areas of very high public access, a risk assessment may indicate that additional controls (e.g. barrier tape, barriers, extra manning) are required.
15. Ensure all operations near to highways are adequately signed with the appropriate notices as specified in the DTLR Code of Practice ***Safety at street works and road works*** (available from The Stationary Office ISBN 0 11 551958 -0)
16. Ensure that the discharge chute is positioned to prevent chips being blown onto the highway during roadside operations, or in any direction where they

can affect colleagues or members of the public.

17. Position the chipper so that operators do not have to stand on embankments/slopes when feeding material into the machine

EMERGENCY PROCEDURES

18. Ensure a designated and responsible person knows the daily work programme and agree with them a suitable emergency contact procedure. Where reasonably practicable use a mobile phone or radio and pre-arrange call-in system.
19. Ensure the operators can provide the emergency services with enough detail for them to be found in the event of an accident, e.g. the grid reference, the distance from the main road, the type of access (suitable for car/four-wheel drive/emergency service vehicles). In urban areas street names are essential. Know the location details before they are needed in an emergency. (Also see AFAG leaflet 802 ***Emergency planning***)

OPERATION

20. Make sure the cuffs of gloves are close fitting or tucked into you're sleeves to stop them being caught on material as it is fed into the chipper.
21. Set the engine speed (and set the stress control if fitted) to obtain optimum performance.
22. Check that material to be chipped is free from stones, metal and foreign objects.
23. Stand to one side of the infeed rollers to avoid being hit by ejected material.
24. Let material go as soon as it is engaged in the infeed rollers or chipping components.

25. Use a push stick at least 1.5 metre long, for both short produce and for the last piece of produce to be chipped.
26. Do not put any part of your body (including hands or feet), into the infeed hopper while the machine is running.
27. Always follow the manufactures' instructions for dealing with blockages on the machine.
28. Keep the area of ground in front of the infeed hopper free from debris to prevent any tripping hazard.
29. Remove the engine start key when the machine is left unattended or when undertaking any maintenance.

FUELLING

30. Stop engine and, if necessary allow the machine to cool before refuelling.
31. Petrol vapour is invisible and can flow considerable distances from spillage or fuelling sites. Maintain a safe distance from any source of ignition at all times.
32. Store fuel to avoid vapour ignition from any source such as fires, people smoking or the wood chipper. Select a site shaded from direct sunlight and away from watercourses and drains.
33. Containers must be clearly labelled and have securely fitting caps. Plastic containers must be designed and approved for use with petrol or diesel fuel.
34. Replace the fuel cap securely.
35. Keep fuel from contacting the skin. If fuel gets into the eyes wash out with sterile water immediately and seek medical advise

Maintenance

36. Ensure the machine is carried out in accordance with the manufacture's handbook.
37. Check chipping components and knives each day for damage and wear.
38. Wear gloves when handling knives.
39. Before working on knives, confirm that the engine is switched off, the start key removed, and the chipping component is stationary.
40. Before opening any guard/cover or reaching into the infeed hopper or discharge chutes make sure that the engine is switched off, start key removed and dangerous parts have come to a stand still.

Maintenance

41. Knives must be changed or reversed if damaged or blunt. Knives must be scrapped when worn to the minimum size specified by the manufacturer.
42. When new/sharpened knives are fitted, ensure that there is the recommended clearance between the knives and the anvil.

MOVING THE MACHINE

43. Stop the engine and remove the start/stop key.
44. Lock the chipping components.
45. Secure the infeed hopper and the chip discharge chute in the transport position.
46. Check the towing bracket, attach, then lift and secure the jockey wheel.
47. Connect the electrics and the safety chain/s to the towing vehicle.

48. Ensure that the load is secure and that people are in a safe position before moving off.

For further leaflets and reading see HSE web site:

www.hse.gov.uk

Further HSE Reading

Mechanical roadside processing AFAG605
Emergency planning AFAG802
Training and certification AFAG805
First aid at work:
 Your questions answered INDG214
Managing health and safety
 In forestry INDG294
Protect your hearing or lose it! INDG363

Further reading Continued

Power-fed mobile wood chippers:
Operator protection at infeed chute AIS38
Power take-offs and power take-off
drive shafts AS24



Risk Assessment

Assessment No: R023-1

Company Name: **GreenMech Ltd**

Activity: ECO-CHIP 150 TRACTOR MOUNTED CHIPPER (EC.150.TMP)

| Hazard | At Risk | Consequence (C) | | Likelihood (L) | | Risk Score | Controls | Revised | | Final Risk Score |
|--|-----------------------------|--|--------|----------------|--------|------------|--|----------|----------|------------------|
| | Those likely to be affected | Likely injury from hazard | Rating | Of incident | Rating | | | C Rating | L Rating | |
| ENTANGLEMENT With cutter in base of CHIPPER infeed chute | OPERATOR | FATALITY – LOSS OF LIMB | 5 | VERY LIKELY | 5 | 25 | Reach area safety distance to cutter complies to latest HSE guidelines. Fix safety stop rail to lower perimeter of infeed chute Operation of this emergency stop system should operate as recommended by HSE. Only appointed operators to use machine (competent) | 5 | 2 | 10 |
| STABBING AND PUNCTURE by projectiles from cutter. Wood, stones, nails rebound back out of infeed chute | OPERATOR | Injuries to face, eyes, head and hands | 3 | QUITE POSSIBLE | 4 | 12 | Trained Operator. Check only green waste is fed into machine. Safety helmet to BSEN 397 Forestry visor Hard wearing gloves with long cuffs | 3 | 3 | 9 |

Key:

| Consequence | Score | Likelihood | Score | To find risk Score multiply consequence rating by the likelihood rating Final revised risk score acceptable to the company is 10 or less. If higher, further controls are required. |
|-----------------------------|-------|-------------------|-------|--|
| Fatality | 5 | Very likely | 5 | |
| Disability | 4 | Quite Possible | 4 | |
| Very serious (broken limbs) | 3 | Possible | 3 | |
| Important (3 day accident) | 2 | Remotely possible | 2 | |
| Noticeable (first aid) | 1 | Improbable | 1 | |

| | |
|--------------|-------|
| Signed: | |
| Date: | |
| Review Date: | |



Risk Assessment

Assessment No: R023-2

Company Name: **GreenMech Ltd**

Activity: ECO-CHIP 150 TRACTOR MOUNTED CHIPPER (EC.150.TMP)

| Hazard | At Risk | Consequence (C) | | Likelihood (L) | | Risk Score | Controls | Revised | | Final Risk Score |
|---|-----------------------------|------------------------------|--------|----------------|--------|------------|---|----------|----------|------------------|
| | Those likely to be affected | Likely injury from hazard | Rating | Of incident | Rating | | | C Rating | L Rating | |
| NOISE | OPERATOR | LOSS OF HEARING | 4 | QUITE POSSIBLE | 4 | 16 | Wear hearing protection to BE EN 352-3. | 4 | 2 | 8 |
| VIBRATION – movement of machine | OPERATOR | BROKEN OR BRUISED LIMB | 3 | POSSIBLE | 3 | 9 | Trained Operator. Lock off handbrake on tractor. Ensure the 4 legs are firmly on the ground. Stand machine on sound, level ground | 3 | 2 | 6 |
| STABBING – PUNCTURE Residue from exhaust chute. Processed green waste | OPERATOR THIRD PARTY | EYE INJURIES CUTS TO FACE | 2 | POSSIBLE | 3 | 6 | Cordon off collection point. Operator to wear head and face protection. Lock off exhaust chute. | 2 | 1 | 2 |

Key:

| Consequence | Score | Likelihood | Score | To find risk Score multiply consequence rating by the likelihood rating Final revised risk score acceptable to the company is 10 or less. If higher, further controls are required. |
|-----------------------------|-------|-------------------|-------|--|
| Fatality | 5 | Very likely | 5 | |
| Disability | 4 | Quite Possible | 4 | |
| Very serious (broken limbs) | 3 | Possible | 3 | |
| Important (3 day accident) | 2 | Remotely possible | 2 | |
| Noticeable (first aid) | 1 | Improbable | 1 | |

| | |
|--------------|-------|
| Signed: | |
| Date: | |
| Review Date: | |



Risk Assessment

Assessment No: R023-3

Company Name: **GreenMech Ltd**

Activity: ECO-CHIP 150 TRACTOR MOUNTED CHIPPER (EC.150.TMP)

| Hazard | At Risk | Consequence (C) | | Likelihood (L) | | Risk Score | Controls | Revised | | Final Risk Score |
|--|-----------------------------|---|--------|----------------|--------|------------|--|----------|----------|------------------|
| | Those likely to be affected | Likely injury from hazard | Rating | Of incident | Rating | | | C Rating | L Rating | |
| ENTANGLEMENT Branches with clothing | OPERATOR | Drawn into cutters – FATALITY – LOSS OF LIMBS | 5 | POSSIBLE | 3 | 15 | Wear snug fitting clothes. No ties, scarves etc. Same controls as for previous hazard of entanglement with cutters. Wear gloves with long cuffs which can be tucked into sleeves | 5 | 2 | 10 |
| IMPACT, SHEAR Fitting link arms and pins in place to connect unit to tractor controls | OPERATOR THIRD PARTY | Injuries to hands. Bruises, cuts. | 2 | POSSIBLE | 3 | 6 | Trained operator Ensure tractor is parked with hand brake applied and engine switched off. | 2 | 1 | 2 |
| STABBING AND PUNCTURE – Handling branches | OPERATOR | CUTS TO HANDS | 2 | QUITE POSSIBLE | 4 | 8 | Wear hard wearing gloves with long cuffs that can be tucked into sleeves. | 2 | 2 | 4 |

Key:

| Consequence | Score | Likelihood | Score | To find risk Score multiply consequence rating by the likelihood rating |
|-----------------------------|-------|-------------------|-------|---|
| Fatality | 5 | Very likely | 5 | |
| Disability | 4 | Quite Possible | 4 | |
| Very serious (broken limbs) | 3 | Possible | 3 | |
| Important (3 day accident) | 2 | Remotely possible | 2 | |
| Noticeable (first aid) | 1 | Improbable | 1 | Final revised likelihood score must be 2 or less |

| | |
|--------------|-------|
| Signed: | |
| Date: | |
| Review Date: | |

Risk Assessment

Assessment No: R0231-4



Company Name: **GreenMech Ltd**

Activity: ECO-CHIP 150 TRACTOR MOUNTED CHIPPER (EC.150.TMP)

| Hazard | At Risk | Consequence (C) | | Likelihood (L) | | Risk Score | Controls | Revised | | Final Risk Score |
|--|-----------------------------|----------------------------------|--------|------------------|--------|------------|---|----------|----------|------------------|
| | Those likely to be affected | Likely injury from hazard | Rating | Of incident | Rating | | | C Rating | L Rating | |
| IMPACT Being struck by branch when feeding green waste into cutters | OPERATOR | BROKEN LIMB BRUISES | 3 | POSSIBLE | 3 | 9 | Stand at side of machine. Trained operator | 3 | 2 | 6 |
| IMPACT, CRUSH, ENTANGLEMENT Connecting Chipmaster to tractor PTO | OPERATOR | BROKEN LIMB, BRUISES, CUTS | 3 | POSSIBLE | 3 | 9 | Trained operator. Examine condition of linkage pins. Ensure tractor is set in parked position and drive shaft is stationary. Set pick up from tractor to correct height. Lock linkage pins in place. Ensure shaft is guarded. | 3 | 1 | 3 |

Key:

| Consequence | Score | Likelihood | Score | To find risk Score multiply consequence rating by the likelihood rating |
|-----------------------------|-------|-------------------|-------|---|
| Fatality | 5 | Very likely | 5 | |
| Disability | 4 | Quite Possible | 4 | |
| Very serious (broken limbs) | 3 | Possible | 3 | |
| Important (3 day accident) | 2 | Remotely possible | 2 | |
| Noticeable (first aid) | 1 | Improbable | 1 | Final revised likelihood score must be 2 or less |

| | |
|--------------|-------|
| Signed: | |
| Date: | |
| Review Date: | |

Eco-TMP

Parts List

Main Chassis

| Fig No | Part Number | Description | Quantity |
|---------------|--------------------|---------------------------------|-----------------|
| | C201321 | No-Stress Box MK111 | 1 |
| | C251808 | Sol Op Directional Valve | 1 |
| | EC150013 | Taper Lock Bush 2517 x 40 | 1 |
| | HYD Kit 19 | Hose Kit (ECO TMP) | 1 |
| | C200950/1 | VIN Serial Number Plate | 1 |
| | C1704100 | Oilite Brush (Flanged) | 2 |
| | C1704101 | Oilite Brush | 1 |
| | C200704 | Complete Set of Decals | 1 |
| | 9413 | Union Jack Flag | 3 |
| | EC150094 | PTO Shaft (ECO TMP) | 1 |
| | EC150078 | Eco TMP Gearbox | 1 |
| | C200909 | Proximity Sensor | 1 |
| | EC150080 | Pulley (Eco TMP) SPB 190 x 2 | 1 |
| | EC150081 | Drive Belt (Eco TMP) SPB 1550 | 2 |
| | EC150082 | Taper Lock (Eco TMP) 2517 x 30 | 1 |
| | EC150083 | Oilite Brush (Eco TMP) | 4 |
| | EC150033/2 | Eco Pivot Arm Tube Machined | 1 |
| | EC151030 | Operating Rod 1025mm | 1 |
| | EC150084 | Gear Box Pin (Eco TMP) | 2 |
| | EC150084/1 | Gear Box Pivot Boss (Eco TMP) | 2 |
| | EC150085 | Top Link Pin (Eco TMP) | 1 |
| | EC150086 | Lower Lift Pin (Eco TMP) | 4 |
| | 9105 | R Clip (Large) | 3 |
| | 9105/1 | R Clip (Medium) | 4 |
| | EC150087 | Leg Pin (Eco TMP) | 4 |
| | EC150088 | Sensor Bracket (Eco TMP) | 1 |
| | PLATINGR025 | Plating Per Machine | 1 |
| | C170476 | Lever Brush | 1 |
| | C170480 | Release Plate Pin | 1 |
| | C170481 | Pivot Brush | 1 |
| | C170482 | Detent Roller Pin | 1 |
| | EC151037 | M6 Grease Nipple Kit RG06 | 1 |
| | EC151040 | Flame Cut Bearing Housing | 1 |
| | C170409 | Document Box | 1 |
| | ECM15025 | Hopper Linch Pin 89419 | 2 |
| | C202117 | 7 Pin Trailer Plug 385418 | 1 |
| | C170454 | Safety Bar Pivot Boss 40mm Long | 2 |

Chipper Chamber

| Fig No | Part Number | Description | Quantity |
|---------------|--------------------|---|-----------------|
| | EC150002 | Chipper Disc Bearing | 1 |
| | EC150024/2 | Shear Bar Bolt Access Hole Blanking Plate | 1 |
| | EC150024/3 | Shear Clamp Plate | 1 |
| | EC150029/1 | Eco Fly Wheel Spacer 30mm | 2 |
| | EC150034/1 | Roller Box Angled Boss | 1 |
| | C204605/2 | 30 x 10 x 12.5 Boss | 2 |

Feed Roller Housing

| Fig No | Part Number | Description | Quantity |
|---------------|--------------------|---------------------------------|-----------------|
| | EC150003 | Roller Bearing | 1 |
| | EC150004 | Roller Motor (keywayed) | 1 |
| | EC150024 | Shear Bar | 2 |
| | EC150026 | Fixed Roller—Bottom | 1 |
| | EC150027 | Moving Roller—Top | 1 |
| | EC150033 | Eco Pivot Arm Boss | 1 |
| | EC150034 | Eco Pivot Pin | 1 |
| | EC150036 | Spring | 1 |
| | EC150004/M | Motor Mounting Block Eco | 1 |
| | C200207/1 | 6 Spline Feed Roller Motor | 1 |
| | C200224 | Oilite Brush | 2 |
| | EC150024/4 | Shear Bar Clamp Plate Boss | 2 |
| | EC150092 | C/S Clamp Block (Front Bearing) | 4 |
| | C170465 | Striker Rod | 1 |

Infeed Chute

| Fig No | Part Number | Description | Quantity |
|---------------|--------------------|--------------------------------------|-----------------|
| | C251813 | Hyd Control Valve (Manual) | 1 |
| | EC150030/2 | Chute Flap Pivot Boss (Eco & Combi) | 2 |
| | EC151036 | Safety Bar Tube | 1 |
| | C170465 | Striker Rod | 1 |
| | C170429 | Detent Roller Nylon | 1 |
| | C170467/1 | Detent Pivot Tube 13mm O/D | 1 |
| | C170467 | Detent Pivot Tube 16mm O/D | 1 |
| | C170475 | Latch Pivot Pin | 1 |
| | EC151035 | Infeed Chute Edging Tube (Isuzu Eco) | 1 |
| | C220407 | Infeed Chute Flapside Edging Tubes | 2 |
| | C180118 | Push Pull Cable | 1 |

Discharge Chute

| Fig No | Part Number | Description | Quantity |
|---------------|--------------------|-----------------------------------|-----------------|
| | C200613 | Clamp Bolt Eco/Combi/170/220 | 2 |
| | EC150030 | Discharge Tube | 1 |
| | N91204 | Nylon Washer 12mm CM250/TMP | 3 |
| | EC150055 | Eco Adjuster Rod | 1 |
| | 9227 | Handle-Grips, Black Ribbed 1' | 2 |
| | EC150055/1 | Plastic End Cap (Use Item 111040) | 7 |
| | C180104 | Discharge Chute Clamp Handle | 1 |

Chipper Disc

| Fig No | Part Number | Description | Quantity |
|---------------|--------------------|---|-----------------|
| | C202503 | Cutter Disc | 2 |
| | EC151039 | Arborist Fly Wheel (4 Cutter) | 1 |
| | EC151255 | Fly Wheel Shaft (Deutz/Isuzu Eco & Eco TMP) | 1 |
| | C150207 | Chipper Pulley (202MT) SPB 315 x 2 | 1 |
| | 81660 | Blade Bolt 202/Eco M16 X 60 12.9 | 2 |
| | EC150029/3 | Eco Fly Wheel Spacer 9mm | 1 |
| | C220204 | Cutter Pocket | 2 |
| | EC151044 | Rear Fly Wheel Bearing | 1 |

Electrics

| Fig No | Part Number | Description | Quantity |
|---------------|--------------------|--------------------------------|-----------------|
| | C201305/13 | 6-Way Flex Socket 489560 | 1 |
| | C203120 | Fibre Washer | 4 |
| | C170432 | Detent Spacer | 1 |
| | C170430 | Detent Spring (Large) T32690 | 2 |
| | C200908 | 3 Way Plug Sensor | 1 |
| | C170430/1 | Detent Spring (Small) E7707020 | 1 |
| | ELEC45 | 8-8-8 Y | 1 |