

QUADTRAK



Operator's Manual

SECTION:**1. Introduction and Purpose****2. Technical Specifications, Dimensions, Noise Level, and Lifting points****3. Safety and Symbols**

- 3.1 Ensure!
- 3.2 Never!
- 3.3 Always!
- 3.4 Safety controls and switches
- 3.5 Control cut-outs
- 3.6 'No Stress' system
- 3.7 Tracking Controls
- 3.8 Symbols on Machine

4. Machine Preparation

- 4.1 Fuelling and parking
- 4.2 Turntable (optional fitting)
- 4.3 Infeed chute
- 4.4 Discharge chute

5. Operation

- 5.1 Pre-work checks
- 5.2 Starting machine
- 5.3 Moving Machine
- 5.4 Stopping machine
- 5.5 Adjustable Feed roller control
- 5.6 Operating Hints
- 5.7 Preparing for Transport on completion of work

6. Maintenance

- 6.1 Routine Maintenance schedule and lubrication points
- 6.2 Engine Oil
- 6.3 Coolant
- 6.4 Hydraulic Oil
- 6.5 Fuel level
- 6.6 Drive belt check
- 6.7 Cutter blades
- 6.8 Radiator
- 6.9 Drive Belt replacement
- 6.10 Steam cleaning

- 6.11 Air cleaner
- 6.12 Electrics
- 6.13 Battery
- 6.14 Wheels and Tyres (optional trailer only)
- 6.15 Brakes (optional trailer only)
- 6.16 Bearings and pivots
- 6.17 Hydraulic connections
- 6.18 Mountings
- 6.19 Hydraulic return filter
- 6.20 Hydraulic Oil change
- 6.21 Fuses and No Stress system
- 6.22 Fault finding chart

7. Storage

- 7.1 Storage
- 7.2 Removal from storage

8. Disposal

9. Appendix

- 9.1 Hydraulic Circuit
- 9.2 Electrical Circuits
- 9.3 Certificate of Conformity
- 9.4 Risk Assessment
- 9.5 Noise Assessment
- 9.6 Parts List
- 9.7 Transcript of HSE leaflet 604

INTRODUCTION

This manual explains the proper operation of your machine. Read these instructions thoroughly before operating and maintaining the machine. Failure to do so could result in personal injury or equipment damage. Consult your GreenMech supplier if you do not understand the instructions in this manual.



CAUTION! This symbol indicates important safety messages in this manual. When you see this symbol, be alert to the possibility of injury to yourself or others, and carefully read the message that follows.

We recommend that you keep this manual with the machine in the box provided. Locate and note here the serial number and quote it in any communications. This is important when ordering spares. Remember to include all numbers and letters.

VIN Number.....

Serial Number.....

Write in the number!

Fig 1.1 Serial Number plate under battery cover.



This manual covers the following models.

QuadTrak 160 self-propelled tracked chipper with dual control bar, and infeed roller speed control. Optional turntable and electric tilting tracks. Optional road trailer.

The information in this manual is correct at the time of publication. However, in the course of development, changes to the machine specification are inevitable. Should you find any information to vary from the machine in your possession please contact your GreenMech dealer for up to date information.

This manual may contain standard and optional features and is not to be used as a machine specification.

PURPOSE



CAUTION! This machine is designed solely to chip wood and must not be used for any other purpose. The machine should only be used by trained operators who are familiar with the content of this instruction manual. It is potentially hazardous to fit or use any parts other than genuine GreenMech parts. The company disclaims all liability for the consequences of such use, which in addition voids the machine warranty.

Fig 2.1 QuadChip Main Features

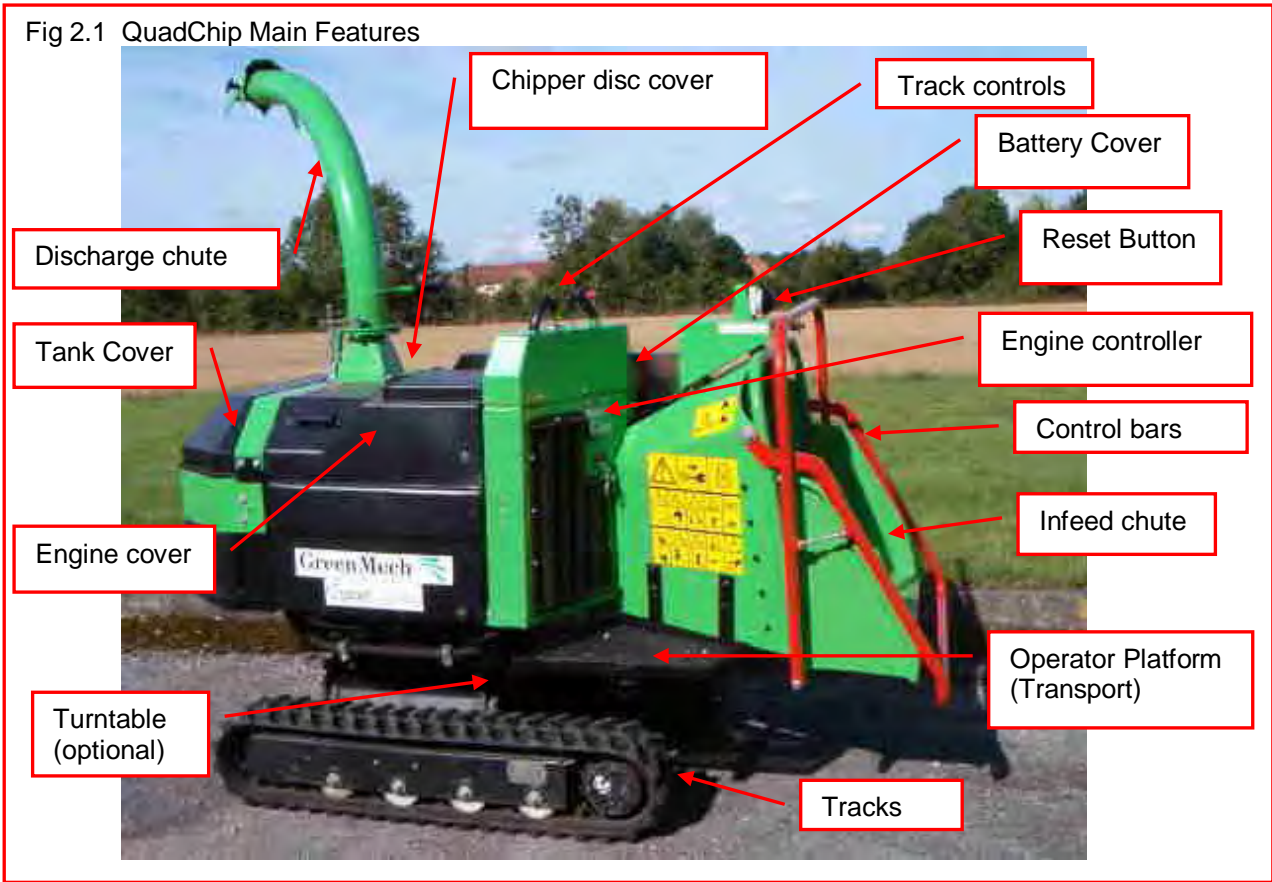

TECHNICAL SPECIFICATION QuadTrak 160	
Max Capacity	230mm X 160mm (9inch x 6inch)
Chipping Disc	500mm x 25mm
Speed	2307 rpm
Chipping Blades	2 Quad Square Blades
Feed Rollers	2 x Hydraulic
Power Control	No-Stress Electronic Feed Roller Controller
Power Unit	Kubota 3 cyl. turbo
Length (Transport)	2368mm
Length (Work)	2368mm
Width (Transport and min. for Work)	1366mm
Height (Storage)	1366mm
Height (Work)	2487mm
Weight	1100kg

Noise

Noise levels vary depending on type of material being processed. Also duration of operation is variable. Noise emission tests have been carried out and the guaranteed sound power level is displayed on the CE plate as follows: **Lwa 114dba**

Minimise noise by switching to idle or stopping the engine whenever chipping is not in progress.



CAUTION! Operators must wear appropriate ear protection. Bystanders must be kept away from proximity of machine.

Lifting Points

There is a single central lifting point by the base of the discharge chute.



CAUTION! Lift with extreme care. The machine may tilt because the single lifting point may not be directly over the centre of gravity.

Trailer

An optional purpose-built road trailer is available.

The chipper may be used whilst secured to the trailer with the trailer hitched to the vehicle. Please refer to this manual for safe use.

Fig 2.2 Trailer (optional)



**3.1 ENSURE:**

- 3.1.1 All Operators must be fully trained in the use of their machine.
(*Certificated Operator training courses are available on request.*)
- 3.1.2 The Operators Manual is read and understood.
- 3.1.3 The enclosed HSE guidance notes are read and understood.
- 3.1.4 Appropriate Personal Protective Equipment (PPE) is worn, including non-slag clothing, gloves, eye and hearing protection.
- 3.1.5 The machine is positioned with the body level.
- 3.1.6
- 3.1.7 All guards are fitted and in good condition.
- 3.1.8 Blades are in good condition and secure.
- 3.1.9 All blades are sharpened or replaced in "Sets".
- 3.1.10 All fasteners are checked regularly for tightness.
- 3.1.11 Only "WOODEN" materials free of nails etc., are fed into the machine.
- 3.1.12 Correct First Aid Kit including large wound dressing is available on site.
- 3.1.13 Fire extinguisher is available on site.

**3.2 NEVER:**

- 3.2.1 Work on the machine until the chipper disc is stationary and engine or PTO has stopped.
- 3.2.2 Operate the machine without protective clothing (Eye protection, Earmuffs, and Gloves), or high visibility clothing when working on roadside.
- 3.2.3 Operate with loose articles of clothing, including loose cuffs on gloves.
- 3.2.4 Work under a raised component without adequate safety support.

- 3.2.5 Operate the machine with untrained personnel or with individuals present who are not involved in the chipping operation.
- 3.2.6 Leave the machine unattended with engine running at full operating speed.
(See section 4)

- 3.2.7 Put any part of your body into the infeed chute while the machine is running.
- 3.2.8 Operate the machine whilst under the influence of alcohol or drugs.
- 3.2.9 Operate inside a building or confined space.
- 3.2.10 Climb on the infeed chute.
- 3.2.11 Impede or obstruct the Stop control.

**3.3 ALWAYS:**

- 3.3.1 Check machine before starting (see Section 4 Preparation and Section 5.1 Operation: Pre-work checks).
- 3.3.2 Be aware of potential hazards in the work area, i.e. uneven ground, tree roots, trip/slip hazards, obstructions and type of materials being fed into the machine.
- 3.3.3 Feed from the side.
- 3.3.4 Keep clear of discharge area.
- 3.3.5 Have a second trained operator within easy reach of the machine.
- 3.3.6 Maintain strict discipline at all times.
- 3.3.7 Service machine at specified periods. (see Section 6: Routine Maintenance).
- 3.3.8 Note direction of discharge chute and if necessary note the wind direction to prevent debris from being blown into highway or where it could affect members of the public.
- 3.3.9 Keep the body level.
- 3.3.10 Check the route to the worksite for gradients, undulations and obstructions.
- 3.3.11 Remove key before doing any maintenance.

Fig 3.4.1 Control Bar and Reset Button

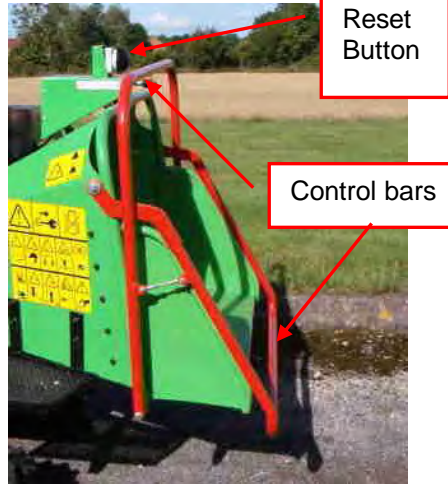

Control Bar positions (Nearside)

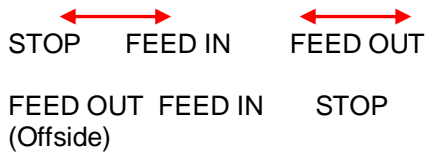
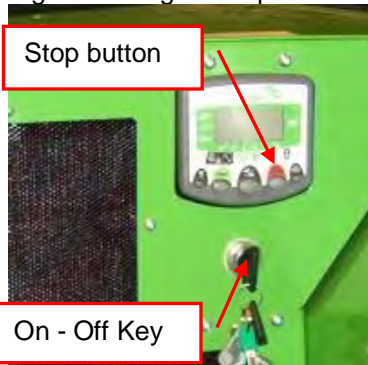

Fig 3.4.2 Engine Stop - Start



3.4 Safety Controls and Switches

3.4.1 Emergency Stop/Control Bars (fig 3.4.1)

In the event of an emergency, push either control bar right in to STOP the feed rollers.

3.4.1.1 Once the emergency has been rectified the following sequence should be carried out:

3.4.1.2 To restart rollers press the reset button, the control bar will have returned to the Feed In position.

3.4.1.3 Should the stop bar be tripped accidentally in normal working conditions, i.e. NOT an emergency, then the rollers can be recovered by performing the above sequence 3.4.1.2.

3.4.1.4 To reverse the rollers (feed out) pull either control bar outwards. To regain forward (feed in) push either control bar back towards the chipper.

3.4.2 Engine Stop button

3.4.2.1 To stop the engine, press the red stop button on the control unit, and/or turn the key anticlockwise to the '0' position. (fig 3.4.2).

3.4.2.2 To restart, reset the key clockwise to 1.

3.4.2.3 To disable the machine, remove the key.

⚠ CAUTION! Do not restart engine until hazard has been removed.

3.5 Control cut-outs

Cut-outs are installed to stop and prevent restarting due to specific events.

3.5.1 Engine overheating is protected by thermal cut-out switch in coolant circuit.

3.5.2 Low engine oil pressure is protected by pressure switch in the engine oil pump.

3.5.4 Discharge chute folded for transport is protected by a microswitch to shut off the fuel solenoid.

3.6 No Stress system

3.6.1 Speed sensor disables feed roller FEED IN or FEED OUT mode when engine speed is below factory pre-set value.

3.6.2 Overload sensor reverses feed to FEED OUT.

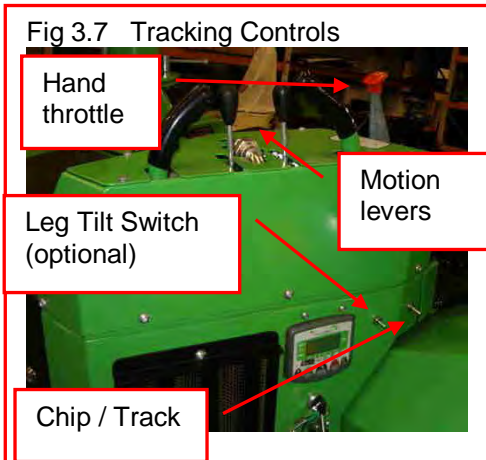

3.7 Tracking Controls (Fig 3.7)

3.7.1 A two position toggle switch selects either tracking or chipping. In track mode the No Stress system will not allow the feed rollers to operate. 3.7.2 (Optional) A three position switch controls the tilt leg. Press in desired direction.

⚠ CAUTION! Take care operating tilt when standing on platform.

3.7.3 Lever controls operate the drives to the tracks. Push for forward motion. Pull for reverse motion.

3.7.4 A hand throttle (fig 3.4.2) is fitted for use only when the machine is being tracked, not when chipping.

Note: The chipper disc runs whenever the engine is running.

Important Safety Information

Caution!

Do NOT drive up or down slopes of more than 20°

Caution!

Do NOT operate or traverse on slopes of more than 30°

Caution! Beware of thrown object hazard

Action: Stand to side of infeed chute, NOT in centre.

Caution! Beware of thrown object hazard

Action: Keep away from fast discharge chute

Caution! Beware Crushing hazard!

Do NOT work or park directly up or down slope.

Face shield must be worn

Wear face shield

Ear defenders must be worn

Wear ear protectors when operating this machine

Sound level

120 dB

Ear defenders must be worn

Lift Point

Caution!

Do not climb into infeed chute

Transport Lock

Lock this component before moving machine

Caution! Infeed chute trapping hazards

Keep hands clear. Do not climb in

Maintenance Information

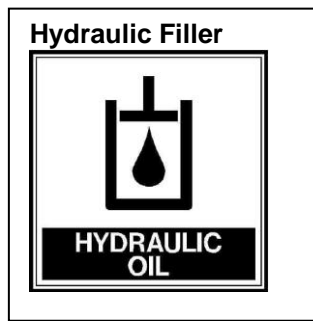
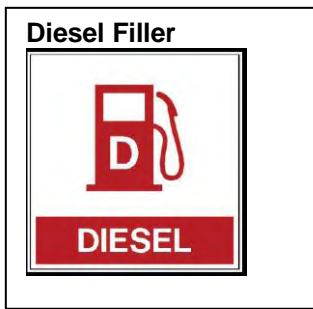

Radiator cleaning

8 Hours Check radiator screen	40 Hours Blow out radiator core

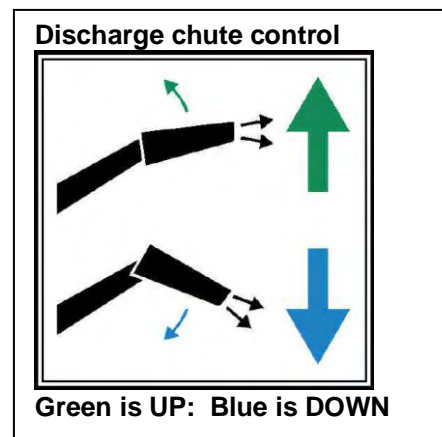

Operating Information

Track drive and throttle controls

Left lever
LH track: forwards – backwards
Right lever
RH track: forwards – backwards
Lever with red knob
Engine throttle slow - fast

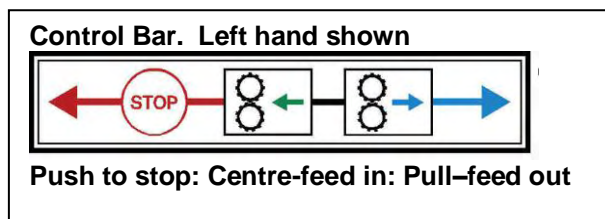
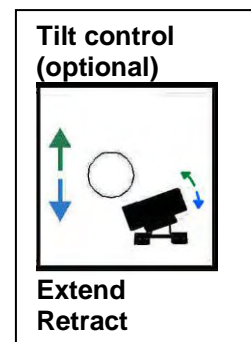
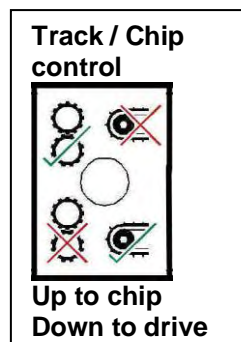
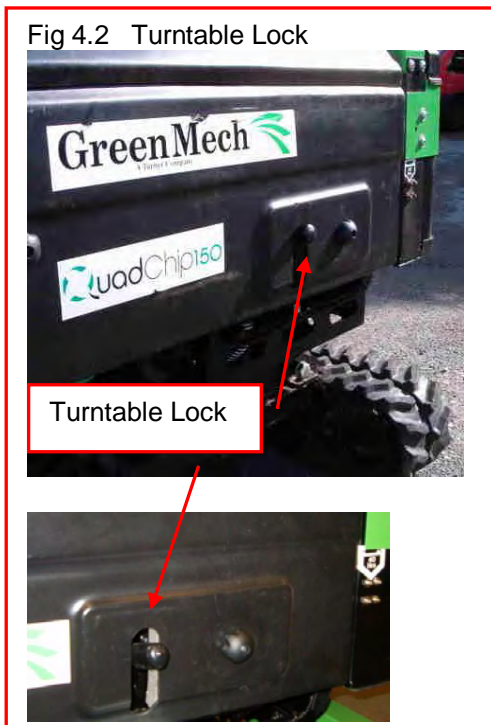

Fig 4.2 Turntable Lock



4.1 Initial Fuelling and Parking

- 4.1.1 Fill the fuel tank with diesel.
- 4.1.2 Top up the hydraulic tank if necessary, with correct oil. See Section 6.
- 4.1.3 Position the machine body level, using the optional tilt if fitted.

If using on optional QuadTrak trailer

- 4.1.4 Keep the trailer attached securely to the vehicle and apply the vehicle handbrake.

4.2 Turntable (optional)

To ease working on sides of busy roads the machine body can be locked in seven different working positions at 45deg steps in relation to the tracks.

- 4.2.1 Lift the locking handle (fig 4.2) and walk the body around to desired position.
- 4.2.3 Ensure that the body locks into new position.

⚠ CAUTION! Before travelling, ensure that the turntable is rotated back into the transport position, and locked.

4.3 Infeed Chute

- 4.3.1 Check that the height of the infeed chute is suitable for ease of working.
- 4.3.2 Press the reset button to enable the control bar to operate for use.

Fig 4.4 Discharge Chute

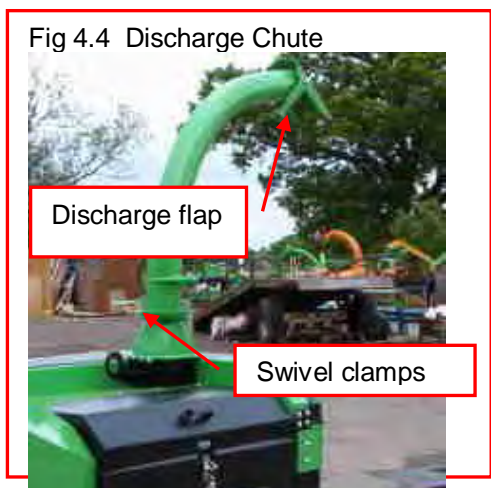

4.4 Discharge Chute (Fig 4.4)

- 4.4.1 Release the swivel clamps, point the chute in the desired direction and tighten the clamps.
- 4.4.2 Set the flap at the desired height and tighten the clamp.

⚠ CAUTION! Do not point the discharge chute towards the infeed area.

⚠ CAUTION! When travelling, lock the discharge chute pointing away from the driver.

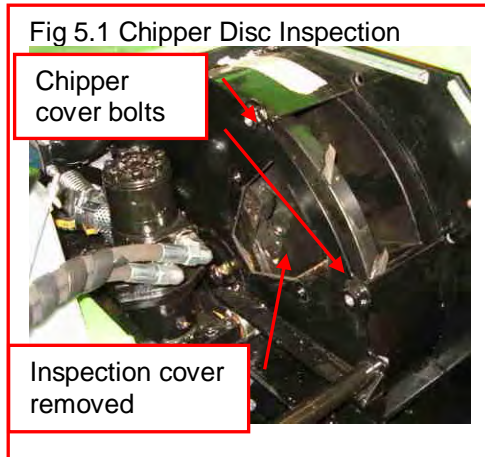

5.1 Pre-Work Checks:

- 5.1.1 Check machine is stationary, Key in OFF position or removed, and hand brake applied if to be used on trailer.
- 5.1.2 Check that machine body is level.
- 5.1.3 Check engine oil level (See Engine instruction manual).
- 5.1.4 Check hydraulic oil level (See Section 6).
- 5.1.5 Check fasteners for tightness and hydraulic connections for leaks.
- 5.1.6 Check condition of disc blades.
- 5.1.6.1 Unlock, raise and secure rear cover and battery cover. Check nothing is rotating.
- 5.1.6.2 Remove chipper disc cover -2 bolts (fig 5.1.1).
- 5.1.6.3 Remove inspection cover -2 bolts.
- 5.1.6.4 Carefully rotate chipper disc to check tightness of disc blade bolts and condition of blades.
- 5.1.6.5 Remove any loose wood material.
- 5.1.6.6 If any bolts are loose, refer to maintenance section for further action.
- 5.1.6.7 Replace inspection cover and chipper disc cover and tighten all bolts securely.
- 5.1.7 Remove any loose material and dust from radiator and engine bay
- 5.1.8 Replace all covers and secure.
- 5.1.9 Check discharge chute is in desired position away from infeed and all clamps are tight. (see Section 4.4)
- 5.1.10 Check work area and erect signs and cone off discharge area if necessary.
- 5.1.11 Check **ALL** safety procedures have been followed.

 **CAUTION!** Beware sharp edges of discs and unexpected movement.

 **CAUTION!** Always work with the chipper level across a slope, preferably with the infeed direction slightly down the slope to minimise the risk of material falling back out.

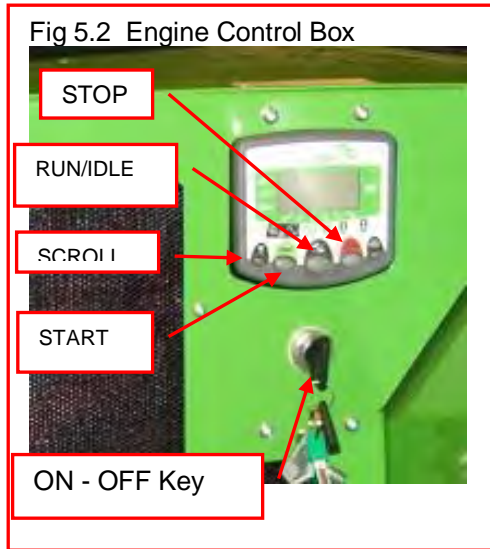

5.2 Starting Machine (Fig 5.2)

5.2.1 Check all other personnel are clear of machine.

5.2.2 Check that feed roller control bar is pushed to the FEED OUT or STOP position, to make the machine safe.

5.2.3 Turn the ON - OFF key to position I. Wait for the pre-glow countdown to cease and chipper speed 0 rev/min to be displayed.

5.2.4 Press green START button to start the chipper.

5.2.5 Press the RUN/IDLE button to increase the speed to operating speed.

5.2.6 Press the reset knob at control bar (fig 3.4.1) to set the control bar ready for work.

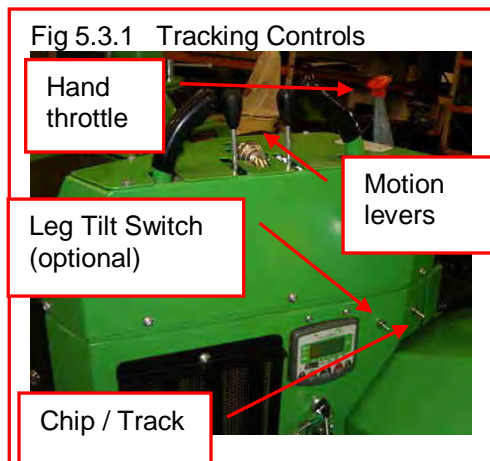

5.3 Moving the Machine

5.3.1 At tracking controls, (fig 5.3.1) Chip / Track, select Track.

5.3.2 **Optional tilt only:** Adjust tilt as required, keeping body level. (fig 5.3.2)

5.3.3 Push both levers together to start forward movement.

5.3.4 Open hand throttle to increase speed. Close to decrease speed.

5.3.5 Push left or right lever to steer.

5.3.6 At work site ensure body is level, using adjustable tilt if fitted.

5.3.7 Close hand throttle to slow engine.

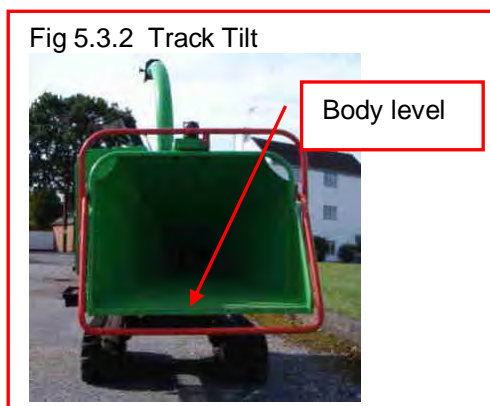

CAUTION! Avoid static turns on hard surfaces. This will rapidly wear the tracks

CAUTION! Point the discharge chute away from the driver. Over long journeys, engage the chipper drive to blow out build up of exhaust gas.

CAUTION! Do not drive directly up slopes exceeding 20 degrees. Slopes up to 30 degrees may be traversed with care.

Fig 5.5 Adjustable feed roller control

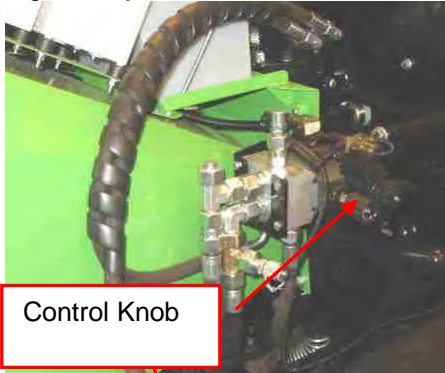

Control knob settings

Material	Setting
up to 120mm	Fully open (3 turns)
120 - 150mm	1/2 to 3/4 turn

5.4 Stopping Machine

- 5.4.1 Push either control bar to STOP position.
- 5.4.2 Press the RUN/IDLE button and allow chipper disc to slow down (fig 5.2).
- 5.4.3 Press red STOP button to stop the engine.
- 5.4.4 Switch ON - OFF key to position 0.
- 5.4.5 Wait for chipper disc to stop.

⚠ CAUTION! The chipper disc will take several seconds to stop due to its inertia.

5.5 Adjustable Speed Feed Roller Control (if fitted)

When chipping wood sizes larger than 120mm diameter it may be necessary to reduce the feed roller speed to suit the material being chipped. The control knob can be carefully accessed from the raised the battery cover to adjust whilst the machine is running.

- 5.5.1 Release the back-nut and turn the valve control knob (fig 5.4) clockwise until valve is closed.
- 5.5.2 Turn the knob anticlockwise to the recommended setting in the table.
- 5.5.3 Tighten the back-nut, lower and secure the cover.

⚠ CAUTION! Do not leave covers open whilst machine is running.

5.6 Operating Hints

5.6.1 Check that chipper disc is at full speed, rpm readout should be above 2300 rpm.

NOTE: The “No Stress” system will only allow FEED IN (Forwards) and FEED OUT operation of the feed rollers when the machine is running at FULL operating speed and not overloaded.

5.6.2 Reduce the chipper speed to IDLE whilst further material is collected for chipping.

5.6.3 Take care when feeding wood into the machine to allow for awkward shapes to “KICK” when contacting the feed rollers.

5.6.4 Position the end of larger sections of wood inside the infeed chute and then support the other end whilst pushing the wood into the feed rollers.

⚠ CAUTION! Do not release discharge chute clamps when chipping is in progress. Elevation of the discharge is altered by means of the adjustable flap (fig. 4.4).

⚠ CAUTION! Keep working area around the machine clear at all times and check only authorised personnel are present.

5.7 Preparing For Transport On Completion Of Work

5.7.1 Check that engine has stopped and chipper disc is stationary.

5.7.2 Remove surplus material from infeed chute and all machine surfaces.

5.7.3 Unlock, lift and secure covers to remove debris.

Optional turntable

5.7.4 Rotate turntable to transport position and ensure it locks.

Note: Preferred position is with track motors at rear when driving on tracks.

⚠ CAUTION! Do not leave machine parked directly up or down slope.

Fig 5.7 Machine ready for transport



- 1) Discharge chute pointing away from operator
- 2) All covers closed and locked
- 3) Turntable set with track motors at rear.

ROUTINE MAINTENANCE SCHEDULE

CAUTION! Always remove key and check for rotation before carrying out any maintenance.

Note: Battery, engine and tank covers are secured closed with a key. They can be secured in raised open position with a prop. Always secure when closed or open.

Action	Section	Page
DAILY		
Check engine oil level and coolant (ref: engine manual)	6.2 – 6.3	6-4
Check hydraulic oil level	6.4	6-4
Check fuel level	6.5	6-4
Check all drive belts	6.6	6-4
Check condition of disc blades and retaining bolts	6.7	6-5
Clean radiator screen and around radiator	6.8	6-6
Check feed roller control bar function	3.4	3-2
Check condition of tracks	Refer to track manual	
Check track gear, nuts, rollers and bearings	Refer to track manual	
First 50 hours		
Check drive belt tension	6.9	6-6
Check battery levels	6.13	6-7
Check hydraulic connections	6.17	6-9
Check all mountings	6.18	6-9
Check feed roller control bar function	3.4	3-2
Service engine	Refer to engine manual	
Weekly in addition to Daily actions		
Blow out radiator core with air line	6.8	6-6
Check drive belt tensions	6.9	6-6
Steam clean machine	6.10	6-6
Clean air cleaner	6.11	6-6
Check electrical connections	6.12	6-7
Check battery levels	6.13	6-7
Check feed roller control bar function	3.4	3-2
Grease all bearings and pivots	6.16, 6.1	6-8
Check hydraulic connections	6.17	6-9
Check all mountings	6.18	6-9
250 hours in addition to Daily and Weekly actions		
Check all fluid levels	6.2, 6.3, 6.4	6-4
Check condition of bearings and pivots	6.16	6-8
Service engine	Refer to engine manual	
Check track gear units, rollers and bearings	Refer to track manual	
Replace return filter element	6.19	6-9
1000 hours in addition to 250 hour actions		
Change hydraulic oil when replacing filter element	6.20	6-9

Trailer (if supplied) refer also to axle manual		
First 50 hours		
Check wheel and tyre condition and pressures	6.14	6-7
Check brake condition and operation	6.15	6-8
Weekly in addition to Daily actions		
Check and adjust brakes	6.15	6-8

ENGINE MAINTENANCE

REFER TO ENGINE MANUAL

TRACK MAINTENANCE

REFER TO TRACK MANUAL

Recommended lubricants	Specification
Hydraulic Oil	ISO 32
Grease	Complex grease EP2 (high temperature)
Engine	SAE 15W-40 APICD

6.1 Lubrication Points (see 6.14)

Fig 6.1 Lubrication points QuadTrak

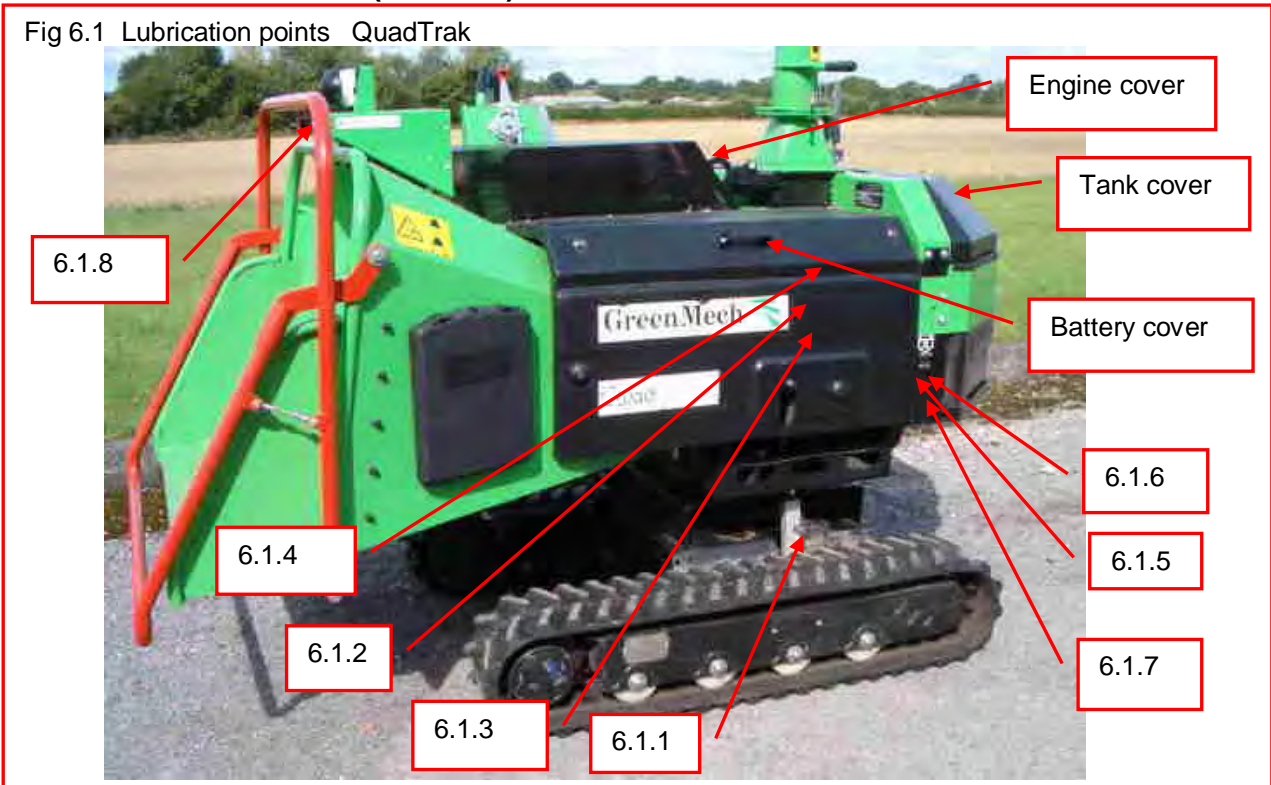

Grease except where stated

6.1.1	Track tilt (if fitted)	Clean and grease sparingly
6.1.2	Feed roller slide	Clean and grease sparingly (Fig 6.1.2)
6.1.3	Sliding Feed roller bearing	1 nipple under battery cover (Fig 6.1.2)
6.1.4	Fixed Feed roller bearing	1 nipple under battery cover (Fig 6.1.2)
6.1.5	Chipper Disc front bearing	1 remote feed nipple (Fig 6.1.3)
6.1.6	Chipper Disc rear bearing	1 remote feed nipple (Fig 6.1.3)
6.1.7	Turntable (if fitted)	2 remote feed nipples (Fig 6.1.3)
6.1.8	Feed Roller control	Clean and grease sparingly

Note 1: Do not over-grease bearings as damage to seals may occur.

Note 2: Use high temperature grease on chipper disc bearings.

Fig 6.1.2 Grease nipples and slides under battery cover

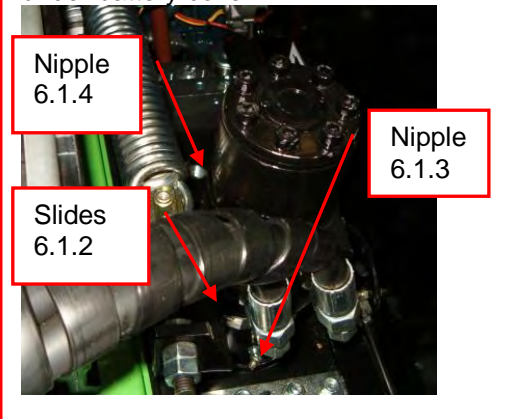

Fig 6.1.3 Remote grease nipples

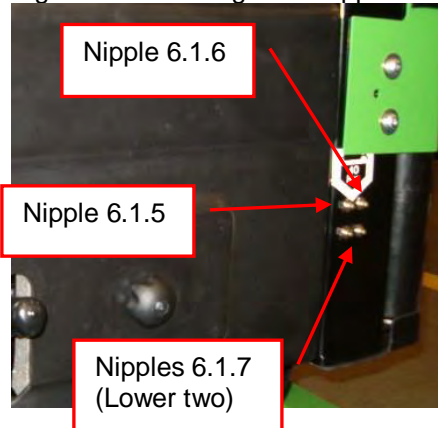
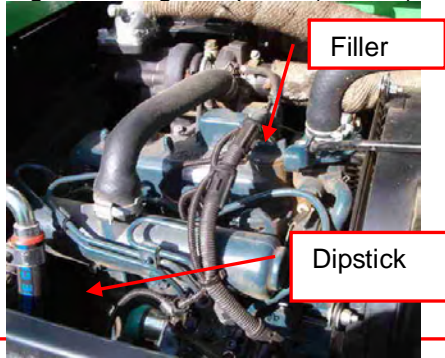

Fig. 6.2b Engine dipstick (Kubota)



6.2 Engine Oil

Under engine cover

6.2.1 Check daily (fig 6.2). Refer to engine manual to refill.

6.3 Coolant

Under battery cover

6.3.1 Check daily, both radiator and overflow tank (fig 6.3). Refill as required. Check antifreeze.

⚠ CAUTION! Do not remove cap when engine is hot.

Fig.6.3 Coolant

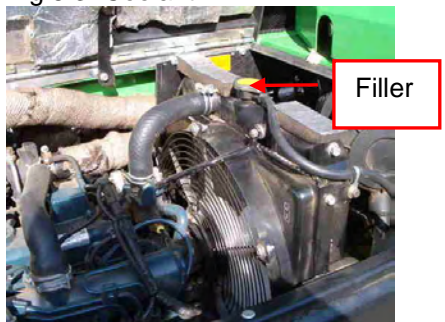

6.4 Hydraulic Oil

Under tank cover

6.4.1 Check daily (fig 6.4). If below mark check for leaks and refill to correct level.

6.4.2 1000 hours. Remove drain plug, drain tank and refill with clean oil of correct specification. Replace filter (6.18)

Fig. 6.4 Under tank cover

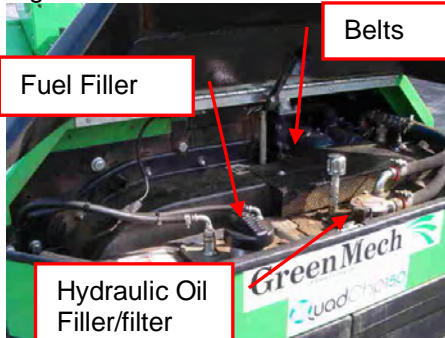

6.5 Fuel Level

Under tank cover

6.5.1 Check daily before work and fill as required (fig 6.4).

⚠ CAUTION! Use clean diesel fuel only. If in doubt, use a funnel with a filter.

⚠ CAUTION! Do not use any form of synthetic fuel.

6.6 Drive Belts

Under tank cover (fig 6.4)

Check daily, before work, the condition of all drive belts and replace if worn. See section 6.9 for further information.

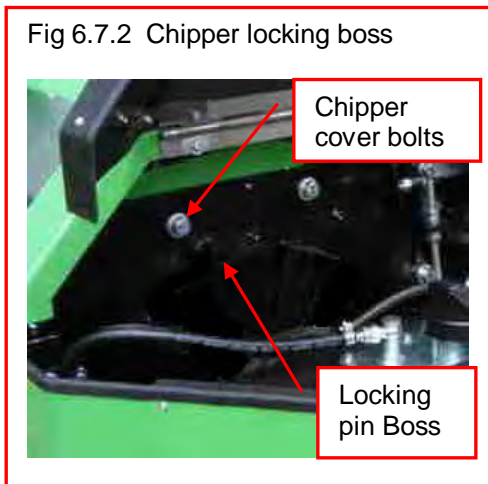
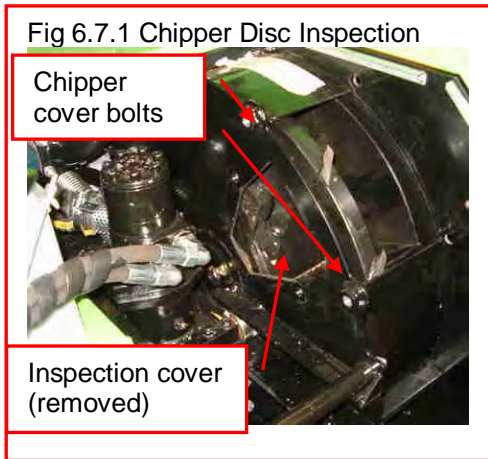

6.7 Cutter Rotation and Replacement

The design of the blades permits relocation in at least three rotated positions before regrinding or replacement is required.

6.7.1 Check engine is switched off and start knob removed.

6.7.2 Raise battery cover and tank cover. Check any rotation has stopped.

6.7.3 Remove the bolts retaining chipper disc cover and inspection cover (fig 6.7.1) and remove covers.

⚠ CAUTION! Take care. Blades are extremely sharp.

6.7.4 Lock the chipper disc with a chipper disc cover bolt or suitable pin through the locking pin boss into a fan blade.

6.7.5 Slacken disc blade retaining bolt, remove cutter, and clean mounting face and location (fig 6.7.2).

6.7.6 Replace cutter in a rotated position to present a sharp section to the shear bars.

6.7.7 Torque up bolt to 150NM (110lb.ft.)

6.7.8 Remove locking pin and rotate disc to next position.

6.7.9 Check condition and security of shear bars. Rotate or replace if required. Do not regrind.

6.7.10 Replace and secure all covers.

⚠ CAUTION! Disc blades must only be sharpened by grinding the angled back face on a bench grinder. Grinding of the front face will upset the gap, which is factory set. Do not sharpen with hand held equipment.

Note. If any of the Disc-Blades are worn below the flat annular section a complete set should be replaced. Inspect condition of nuts and bolts and replace if any signs of wear.

All blades must be sharpened in “sets” with equal amounts removed to maintain balance.

Fig 6.8 Radiator

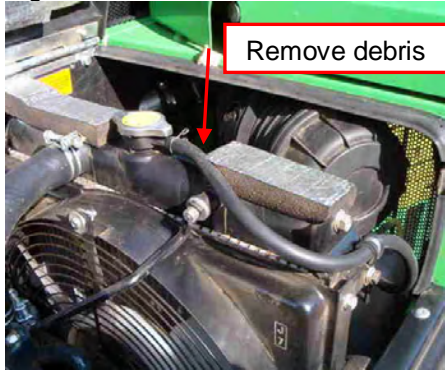

6.8 Radiator (under engine cover)

Daily

6.8.1 Check radiator for debris. (fig.6.8)

50 hours or weekly

6.8.2 In addition to above, blow out radiator core from back with suitable airline and clear from front.

⚠ CAUTION! A build up of debris risks overheating of the engine and a risk of fire.

Fig 6.9.1 Drive Belts

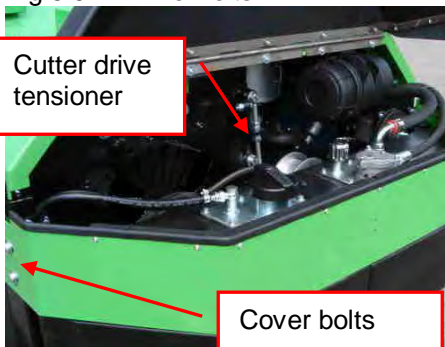

6.9 Drive belts

Belt Replacement

6.9.1 Remove tank covers from machine (fig 6.9.1).

6.9.2 Hinge tanks away from drive belt area (fig 6.9.2).

Cutter Drive

6.9.3a Remove fan covers.

6.9.4a Release nuts on idler pulley tensioner bar until belts are slack enough to be removed.

Pump drive

6.9.3b Release 4 bolts in slotted pump mounting plate to permit belts to be removed.

6.9.5 Fit new set of belts ensuring they lay snugly in pulley grooves.

6.9.6a Screw nuts on tensioner bar to re-tension belts.

6.9.6b With suitable bar ease pump plate upwards to tighten belts and secure plate with bolts.

6.9.7 Check tension.

6.9.8 Replace fan cover if removed, reposition tanks, replace all covers and secure.

Fig 6.9.2.1 Drive Belt access

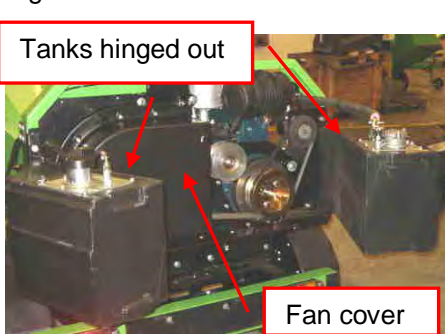

6.10 Steam Cleaning

weekly and every 250 hours

6.10.1 Check all covers are fitted and closed.

6.10.2 Steam clean machine surfaces.

6.10.3 Clean electrical components with a damp rag, spray with WD40 and then wipe with dry rag.

⚠ CAUTION! Do not steam clean directly on to electrical components, e.g. control boxes.

Fig 6.9.2.2 Drive Belt adjustments

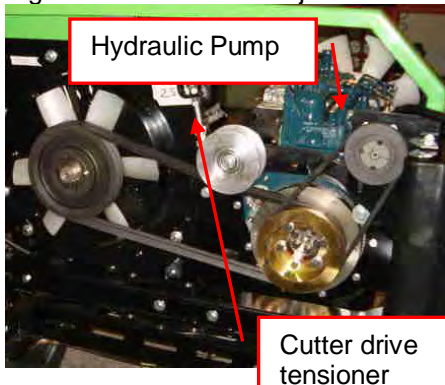

Fig 6.11 Air Cleaner



Air Cleaner

6.11 Air Cleaner (under tank cover) Weekly (Refer to engine manual)

6.11.1 Remove cover clips (fig 6.11) and release.

6.11.2 Slide out element and either blow out with air-line or gently tap on smooth ground to release debris.

6.11.3 Replace cover.

6.12 Electrical connections weekly

6.12.1 Check all wiring loom connections are secure.

⚠ CAUTION! Poor connections will affect engine security cut-outs and may prevent starting.

6.13 Battery

First 50 hours and weekly

6.13.1 Raise and secure battery cover.

6.13.2 Release stays to access battery.

6.13.2 Check electrolyte level and top up if required.

6.13.3 Reposition battery, and secure stays.

6.13.4 Lower cover and secure.

Removal

6.13.5 First disconnect negative (-) cable (black cap).

6.13.6 Disconnect positive (+) cable (red cap).

6.13.7 Remove clamp and carefully lift out battery.

6.13.8 Replace by connecting positive cable before negative.

6.13.9 Secure battery as 6.13.3 above.

⚠ CAUTION! Gases are explosive. Electrolyte is corrosive. Avoid sparks and spillage.

Fig 6.13 Battery

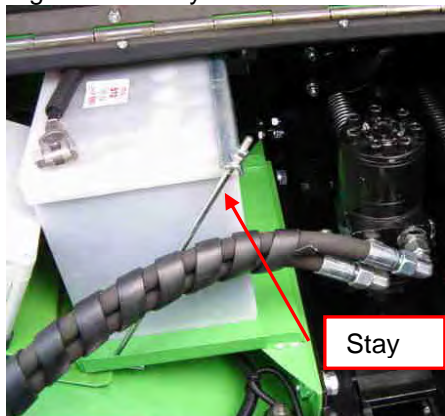

Stay

Fig 6.15.1 Brake adjustment



6.14 Tyres and Wheels of Trailer
50 hours and 250 hours

- 6.14.1 Check condition of tyres.
- 6.14.2 Check pressures and inflate to 2.7bar (40lb/in²) pressure as required.
- 6.14.3 Check wheel nuts are tight to 110Nm (80lbft) torque.

6.15 Brakes of Trailer
50 hours, weekly and 250 hours

- 6.15.1 Check operation and effectiveness of overrun and handbrake.

100 hours

Adjust brakes as follows

- 6.15.2 Chock machine, release handbrake fully off and check drawbar is fully extended.
- 6.15.3 Jack up both wheels and support on axle stands.
- 6.15.4 Remove inner bung to expose adjuster 'starwheel' (fig 6.15.1).
- 6.15.5 Adjust starwheel with screwdriver until tight whilst rotating each wheel forwards until tight.
- 6.15.6 Slacken until wheel rotates freely in forward direction.
- 6.15.7 Check brake linkage has 4 to 6mm movement at cable.
- 6.15.8 Repeat for opposite wheel.
- 6.15.9 Check balance bar is straight and pulls both cables evenly (fig 6.15.2).
- 6.15.10 Adjust the ballnut to remove any slack from brake rod.

Note: Servicing of brakes may be required more often if above average mileage is covered.

Refer to AL-KO brake manual or GreenMech for details for brake shoe replacement and other servicing

⚠ CAUTION! Reverse rotation of wheel may prevent correct adjustment.

Fig 6.15.2 Brake adjustment

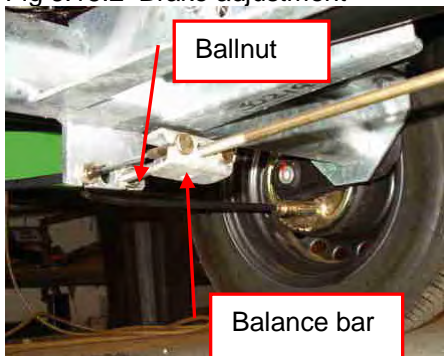
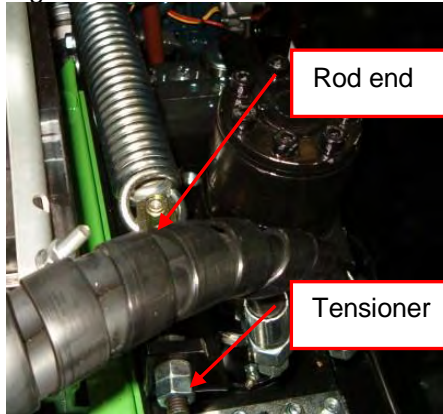

Fig 6.16 Feed roller tensioner



6.16 Bearings and Pivots

weekly

See paragraph 6.1 for routine lubrication.

250 hours

6.16.1 Check rotating components for excessive movement and noise in operation.

6.16.2 Replace as required.

6.16.3 Release spring retainer to clean feed roller slides. (Fig 6.16)

6.16.3.1 Slacken tensioner

6.16.3.2 Unclip rod end pin and release.

6.16.3.3 Replace and retension after cleaning.

6.17 Hydraulic connections

50 hours

6.17.1 With the aid of the circuit diagram to follow the hose routings, check all hoses and connections for leaks and damage.

6.17.2 Replace any worn or damaged hoses with the correct type and length.

6.17.3 Before removal, check routing and ensure replacement hose is fitted free of strains, twists or kinks.

! CAUTION! Ensure any residual pressure is released before dismantling.

! CAUTION! Ensure hoses are refitted free of twists and kinks.

Fig 6.19 Hydraulic Return Filter

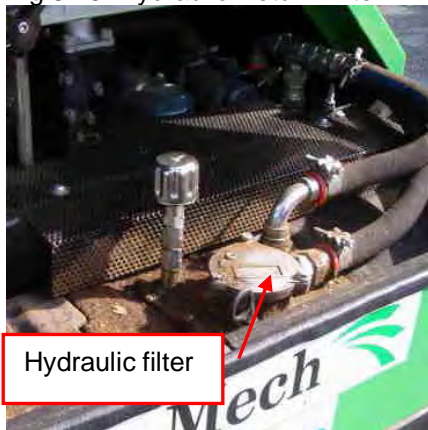

6.18 Mountings

250 hours

6.18.1 Check that all mounting bolts are tight.

6.19 Hydraulic Return Filter

250 hours

6.19.1 Check oil is cool.

6.19.2 Unscrew the filter cover (there is a spring under the cover) and carefully lift out the element, it may require gentle prising out, discard safely (fig 6.19).

6.19.3 Fit a new filter element to the correct specification and replace the cover and spring.

! CAUTION! Do not overtighten.

6.20 Hydraulic Oil change

1000 hours

6.20.1 Remove hydraulic oil with suction pump at filter/filler and replace with new oil and filter of correct specification.

6.20.2 Replace suction filter.

6.20.3 Dispose of waste oil according to local authority environmental procedures.

6.21 Fuses and No Stress system

There are two fuses.

A 40 amp in-line fuse protects the engine pre-heat and start circuit.

A 20 amp fuse protects the Power Protection System.

Note The engine operating speeds for the No Stress system are factory set for particular machine builds and must not be readjusted.

6.22 Fault finding

Fault	Check	Action	Page
Engine will not start	Covers and discharge chute cut-out switches	Secure all covers and Chute	
	Battery	Recharge	6-7
	Fuel	Fill tank	6-4
	Oil pressure	Check Oil level	6-4
	Thermal cut-out	Check operation	6-4
	Fuses	Check	6-10
Engine not at correct speed	Engine control	Check operation	5-2
Blade disc will not start	Drive belts	Replace	6-6
Feed rollers do not turn	Control bar	Reset and check	3-2
	Hydraulics	Check solenoid valve	
Feed will not reverse	Control bar	Reset and check	3-2
	Hydraulic valve	Check operation	
Discharge does not flow	Discharge chute	Check for blockage	4-2
	Blade disc	Check for blockage	5-1
Unusual noise(s)	Blade disc and bearings	Check and replace	5-1

7.1 Storage

7.1.1 Thoroughly clean machine and note any replacement parts required.

7.1.2 Carry out 250 hour service if not already done. Refer to Section 6

7.1.3 Fit replacement parts when available.

7.1.4 Remove battery Refer to 6.13

7.1.5 Drain fuel

Note: Discharge chute may be lowered carefully over body to reduce height.

7.2 Removal from Storage

7.2.1 Charge battery and refit Refer to 6.13

7.2.2 Raise discharge chute and secure (if lowered)

7.2.3 Carry out machine preparation as necessary Refer to Section 4

When the machine is finally scrapped, the following items should be disposed of only at authorised waste disposal facilities.

Engine oil. Hydraulic oil. Antifreeze. Battery. Tracks.

If in doubt, consult the Local Authority environmental department.

Major non-ferrous items such as covers and hydraulic hoses may also be disposed of separately.

DO NOT SCALE - IF IN DOUBT ASK

1ST ANGLE PROJECTION

DIMNS IN MM

PROGRAM No:-

Assembly	Sub Assembly	Number
QuadChip Chipper	Chipper Body	QC-160
	Control Box Cover	QTRAK-039
	Control Box Base	QTRAK-016
	Infeed Extension	QTRAK-049
	Lower Safety Bar	QTRAK-037
QuadTRAK Chassis	Chassis Fabrication	QTRAK-001
	Tilt/Rotate Platform	QTRAK-002
	Caterpillar Track RH	QTRAK-063
	Caterpillar Track LH	QTRAK-064
	Foot Platform Assembly	QTRAK-023
	Tilt Hinge Fab	QTRAK-009
	Linear Actuator	QTRAK-065

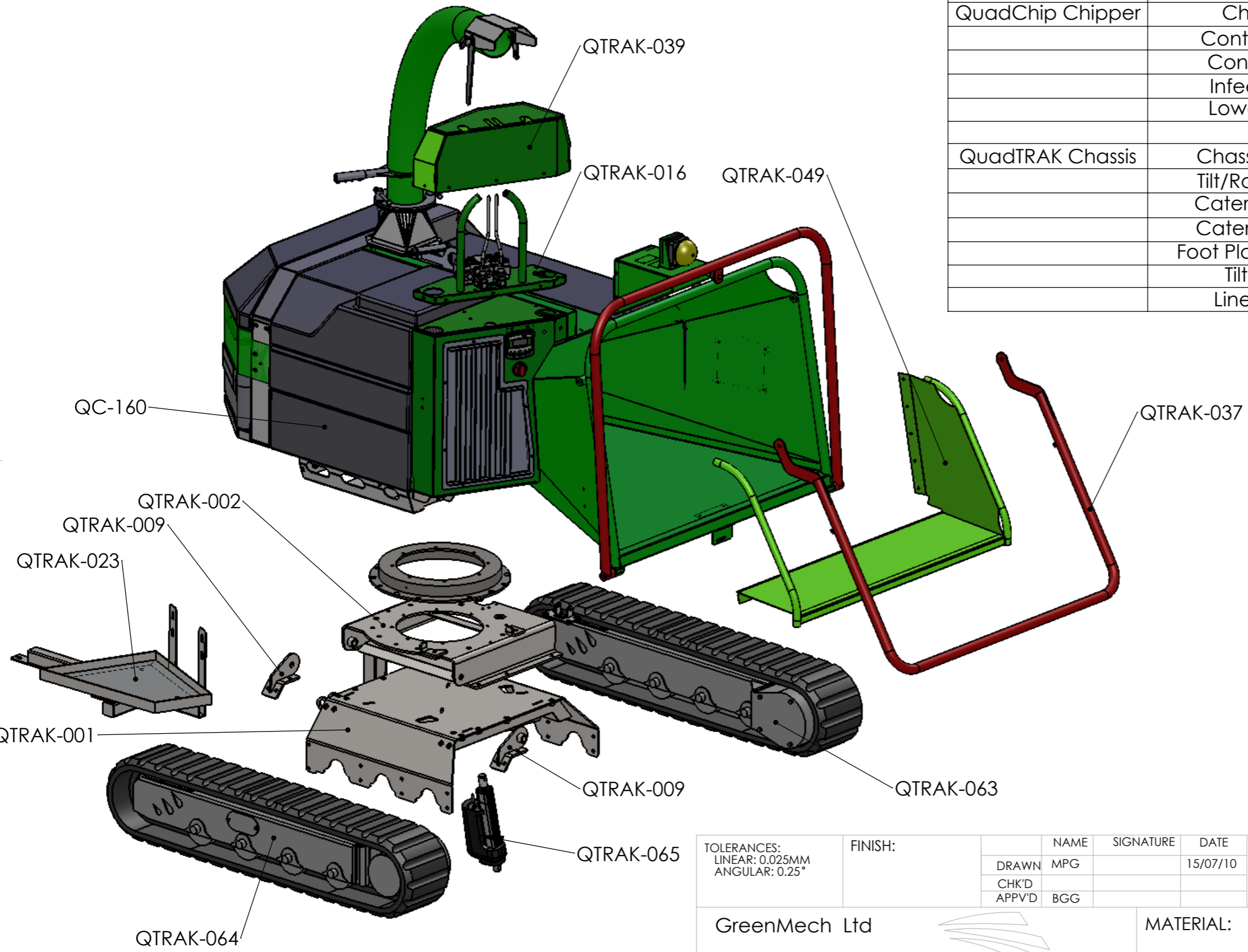

TOLERANCES:
 LINEAR: 0.025MM
 ANGULAR: 0.25°

FINISH:

	NAME	SIGNATURE	DATE	DEBUR AND BREAK SHARP EDGES
DRAWN	MPG		15/07/10	
CHK'D				
APPVD	BGG			

TOLERANCES
 MACHINED PARTS +/- 0.025mm
 FABRICATED PARTS +/- 1.0mm

GreenMech Ltd
 The Mill Industrial Park
 Kings Coughton
 Alcester
 Warks B49 5QG Tel 01789 400044

MATERIAL:

TITLE:
 Upper and lower assemblies

WEIGHT:

Complete Quadtrak Exploded Assembly

REV A	MODIFICATION	DRN	APPD	DATE
1				
2				
3				

SCALE:1:50

SHEET 1 OF 1

DO NOT SCALE - IF IN DOUBT ASK

1ST ANGLE PROJECTION

DIMNS IN MM

PROGRAM No:-

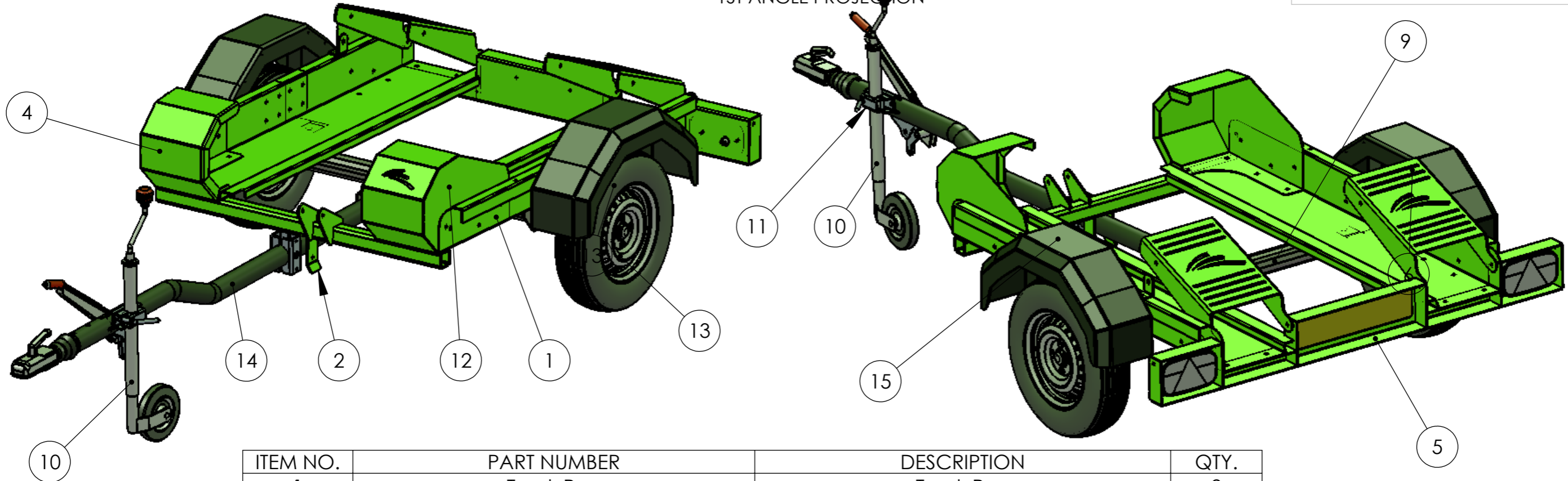

ITEM NO.	PART NUMBER	DESCRIPTION	QTY.
1	Track Pan	Track Pan	2
2	Front Transverse Assembly	Front Transverse Assembly	1
3	Jack Pivot Clamp	Jack Pivot Clamp	2
4	Front Track Stop RH	Front Track Stop	1
5	Lightboard 5mm	Lightboard Assembly	1
6	Rear Ramp	Rear Ramp	2
7	Fixed Pivot Assembly	Fixed Pivot Assembly	2
8	Moving Pivot Assembly	Moving Pivot Assembly	2
9	ALCO Widened Axle Drawbar Assembly	ALCO Widened Axle Drawbar Assembly	1
10	QC160-1-1022	JOCKEY WHEEL	1
11	JWC	Jockey Wheel Clamp	1
12	Front Track Stop LH	Front Track Stop LH	1
13	QC160-1-1023	WHEEL AND TYRE	2
14	QC160-1-1001	Drawbar Assembly	1
15	QC160-1-1012	QUAD CHIP MUDGUARD ASSY	2
16	Complete Quadtrak	Upper and lower assemblies	1
17	Tail Latch Bracket	Tail Latch Bracket	2

TOLERANCES:
LINEAR: 0.025MM
ANGULAR: 0.25°

FINISH:

NAME	SIGNATURE	DATE
MPG		04/08/10
CHK'D		
APPVD	BGG	

DEBUR AND
BREAK SHARP
EDGES

TOLERANCES
MACHINED PARTS +/- 0.025mm
FABRICATED PARTS +/- 1.0mm

GreenMech Ltd
The Mill Industrial Park
Kings Coughton
Alcester
Warks B49 5QG Tel 01789 400044

MATERIAL:

TITLE:
QT Trailer GA

WEIGHT:

DWG NO. QT Trailer GA

A3

REV A	MODIFICATION	DRN	APPD	DATE
1				
2				
3				

SCALE:1:50

SHEET 1 OF 1